

Excellent Integrated System Limited

Stocking Distributor

Click to view price, real time Inventory, Delivery & Lifecycle Information:

[Molex Connector Corporation](#)

[14-60-0221](#)

For any questions, you can email us directly:

sales@integrated-circuit.com

OPTION A

NOTES:

- MATERIAL:**
HOUSING: POLYESTER(PBT), GLASS FILLED, UL94 V-0,
COLOR: BLACK
TERMINAL: PHOSPHOR BRONZE
- FINISH:**
TIN: 3.81 MICROMETERS/150 MICROINCHES MINIMUM TIN
OVER NICKEL UNDERPLATE OVERALL
- TO BE USED WITH 24 AWG STRANDED WIRE WITH (1.35)/.053 DIAMETER MAXIMUM INSULATION
- SEE TABLE FOR AVAILABLE CIRCUIT SIZES
- STANDARD PACKAGING PER PK-70873-0001, OPTIONAL PACKAGING MAY BE AVAILABLE, REQUEST DRAWING PK-70400
- PARTS STACKABLE END TO END ON (2.54)/.100 CENTERS
- PRODUCT SPECIFICATION: PS-70400
- SEE DRAWING SDA-70400-**** (SHEET 3) FOR OPTIONAL HOUSING DETAILS
- 4 CIRCUIT SHOWN
- TO MATE WITH MOLEX 2.54/.100 CENTERLINE HEADERS
- 2 CIRCUIT ASSEMBLIES SUPPLIED AS GROUPED PAIRS

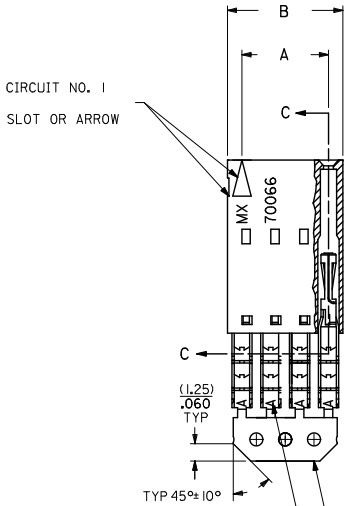
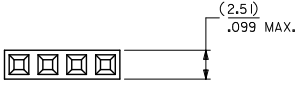

SECTION C-C

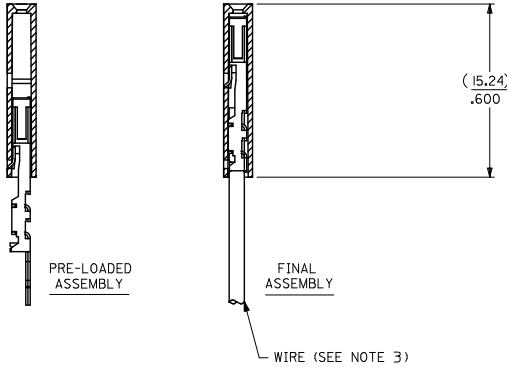

I.D. SLOT CODE TO WIRE GAUGE CHART	
I.D. SLOT CODE	WIRE GAUGE
A	24 AWG.

PLATING CODE (STRIPE ON CARRIER STRIP)	
PLATING	COLOR
TIN	NONE

REMOVE ENG. NO. EC NO: UC2201F-110 DRAWN BY: MSIBARRA 2010/10/19 CHECKED BY: CHKDORGAN 2010/10/19 APPROVED BY: JAPRSMILLER 2010/11/24	QUALITY SYMBOLS ∇=0 ∇=0 ∇=0	GENERAL TOLERANCES (UNLESS SPECIFIED) 4 PLACES ± --- ± --- 3 PLACES ± --- ± .010 2 PLACES ± 0.25 ± .014 1 PLACE ± 0.35 ± --- ANGULAR ±1/2°	DIMENSION STYLE MM/IN	DRAWN BY: MSIBARRA 2010/10/19 CHECKED BY: DATE WAZ 1984/10/09 APPROVED BY: DATE MILLER 2010/11/24	SCALE: DESIGN UNITS INCH TITLE: ASSEMBLY, SL CONNECTOR SINGLE ROW 2.54/.100 GRID MOLEX INCORPORATED	MATERIAL NO. SDA-70400-0001-0024 DOCUMENT NO. SHEET NO. 1 OF 1

CKT. SIZE	A	B	EDP. NO.
2	(2.54) .100	(5.05) .199	I4-60-0021
3	(5.08) .200	(7.59) .299	I4-60-0031
4	(7.62) .300	(10.13) .399	I4-60-0041
5	(10.16) .400	(12.67) .499	I4-60-0051
6	(12.70) .500	(15.21) .599	I4-60-0061
7	(15.24) .600	(17.75) .699	I4-60-0071
8	(17.78) .700	(20.29) .799	I4-60-0081
9	(20.32) .800	(22.83) .899	I4-60-0091
10	(22.86) .900	(25.37) .999	I4-60-0101
11	(25.40) 1.000	(27.91) 1.099	I4-60-0111
12	(27.94) 1.100	(30.45) 1.199	I4-60-0121
13	(30.48) 1.200	(32.99) 1.299	I4-60-0131
14	(33.02) 1.300	(35.53) 1.399	I4-60-0141
15	(35.56) 1.400	(38.07) 1.499	I4-60-0151
16	(38.10) 1.500	(40.61) 1.599	I4-60-0161
17	(40.64) 1.600	(43.15) 1.699	I4-60-0171
18	(43.18) 1.700	(45.69) 1.799	I4-60-0181
19	(45.72) 1.800	(48.23) 1.899	I4-60-0191
20	(48.26) 1.900	(50.77) 1.999	I4-60-0201
21	(50.80) 2.000	(53.31) 2.099	I4-60-0211
22	(53.34) 2.100	(55.85) 2.199	I4-60-0221
23	(55.88) 2.200	(58.39) 2.299	I4-60-0231
24	(58.42) 2.300	(60.93) 2.399	I4-60-0241
25	(60.96) 2.400	(63.47) 2.499	I4-60-0251