

Excellent Integrated System Limited

Stocking Distributor

Click to view price, real time Inventory, Delivery & Lifecycle Information:

[Semtech](#)
[SX8634EVK](#)

For any questions, you can email us directly:

sales@integrated-circuit.com

SX8634



Low Power, Capacitive Button and Slider Touch Controller
 (12 sensors) with Enhanced LED Drivers and Proximity Sensing

ADVANCED COMMUNICATIONS & SENSING DATASHEET

GENERAL DESCRIPTION

The SX8634 is an ultra low power, fully integrated 12-channel solution for capacitive touch-buttons and slider applications and proximity detection. Unlike many capacitive touch solutions, the SX8634 features dedicated capacitive sense inputs (that requires no external components) in addition to 8 general purpose I/O ports (GPIO). Each GPIO is typically configured as LED driver with independent PWM source for enhanced lighting control such as intensity and fading.

The SX8634 includes a capacitive 10 bit ADC analog interface with automatic compensation up to 100pF. The high resolution capacitive sensing supports a wide variety of touch pad sizes and shapes and allows capacitive buttons to be created using thick overlay materials (up to 5mm) for an extremely robust and ESD immune system design.

The SX8634 incorporates a versatile firmware that was specially designed to simplify capacitive touch solution design and offers reduced time-to-market. Integrated multi-time programmable memory provides the ultimate flexibility to modify key firmware parameters (gain, threshold, scan period, auto offset compensation...) in the field without the need for new firmware development.

The SX8634 supports the 400 kHz I²C serial bus data protocol and includes a field programmable slave address. The tiny 5mm x 5mm footprint makes it an ideal solution for portable, battery powered applications where power and density are at a premium.

KEY PRODUCT FEATURES

- ◆ Complete Twelve Sensors Capacitive Touch Controller for Buttons and Slider
 - Pre-configured for 6 Buttons and a Slider
 - 8 LED Drivers with Individual Intensity, Fading Control and Autolight Mode
 - 256 steps PWM Linear and Logarithmic control
- ◆ Proximity Sensing up to several centimetres
- ◆ High Resolution Capacitive Sensing
 - Up to 100pF of Offset Capacitance Compensation at Full Sensitivity
 - Capable of Sensing through Overlay Materials up to 5mm thick
- ◆ Extremely Low Power Optimized for Portable Application
 - 8uA (typ) in Sleep Mode
 - 80uA (typ) in Doze Mode (Scanning Period 195ms)
 - 220uA (typ) in Active Mode (Scanning Period 30ms)
- ◆ Programmable Scanning Period from 15ms to 1500ms
- ◆ Auto Offset Compensation
 - Eliminates False Triggers due to Environmental Factors (Temperature, Humidity)
 - Initiated on Power-up and Configurable Intervals
- ◆ Multi-Time In-Field Programmable Firmware Parameters for Ultimate Flexibility
 - On-chip user programmable memory for fast, self contained start-up
- ◆ "Smart" Wake-up Sequence for Easy Activation from Doze
- ◆ No External Components per Sensor Input
- ◆ Internal Clock Requires No External Components
- ◆ Differential Sensor Sampling for Reduced EMI
- ◆ 400 KHz Fast-Mode I²C Interface with Interrupt
- ◆ -40°C to +85°C Operation

TYPICAL APPLICATION CIRCUIT

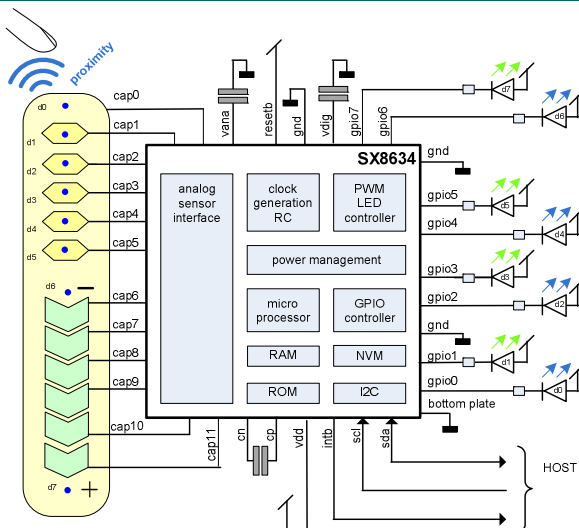

APPLICATIONS

- ◆ Notebook/Netbook/Portable/Handheld computers
- ◆ Cell phones, PDAs
- ◆ Consumer Products, Instrumentation, Automotive
- ◆ Mechanical Button Replacement

ORDERING INFORMATION

Part Number	Temperature Range	Package
SX8634105AWLTRT ¹	-40°C to +85°C	Lead Free MLPQ-W32

¹ 3000 Units/reel

* This device is RoHS/WEEE compliant and Halogen Free



SX8634
 Low Power, Capacitive Button and Slider Touch Controller
 (12 sensors) with Enhanced LED Drivers and Proximity Sensing

ADVANCED COMMUNICATIONS & SENSING DATASHEET

Table of Contents

GENERAL DESCRIPTION.....	1
TYPICAL APPLICATION CIRCUIT	1
KEY PRODUCT FEATURES.....	1
APPLICATIONS.....	1
ORDERING INFORMATION.....	1
1 GENERAL DESCRIPTION.....	4
1.1 Pin Diagram	4
1.2 Marking information	4
1.3 Pin Description	5
1.4 Simplified Block Diagram	6
1.5 Acronyms	6
2 ELECTRICAL CHARACTERISTICS	7
2.1 Absolute Maximum Ratings	7
2.2 Recommended Operating Conditions	7
2.3 Thermal Characteristics	7
2.4 Electrical Specifications	8
3 FUNCTIONAL DESCRIPTION.....	10
3.1 Quickstart Application	10
3.2 Introduction	10
3.2.1 General	10
3.2.2 GPIOs	11
3.2.3 Parameters	11
3.2.4 Configuration	11
3.3 Scan Period	12
3.4 Operation modes	12
3.5 Sensors on the PCB	14
3.6 Button and Slider Information	15
3.6.1 Button Information	15
3.6.2 Slider Information	15
3.7 Analog Sensing Interface	17
3.8 Offset Compensation	18
3.9 Processing	19
3.10 Configuration	19
3.11 Power Management	21
3.12 Clock Circuitry	21
3.13 I2C interface	21
3.14 Reset	22
3.14.1 Power up	22
3.14.2 RESETB	22
3.14.3 Software Reset	23
3.15 Interrupt	24
3.15.1 Power up	24
3.15.2 Assertion	24
3.15.3 Clearing	24



SX8634
 Low Power, Capacitive Button and Slider Touch Controller
 (12 sensors) with Enhanced LED Drivers and Proximity Sensing

ADVANCED COMMUNICATIONS & SENSING DATASHEET

3.15.4	Example	25
3.16	General Purpose Input and Outputs	25
3.16.1	Introduction and Definitions	25
3.16.2	GPI	26
3.16.3	GPP	26
3.16.4	GPO	27
3.16.5	Intensity index vs PWM pulse width	30
3.17	Smart Wake Up	31
4	PIN DESCRIPTIONS	32
4.1	Introduction	32
4.2	ASI pins	32
4.3	Host interface pins	33
4.4	Power management pins	36
4.5	General purpose IO pins	37
5	DETAILED CONFIGURATION DESCRIPTIONS	38
5.1	Introduction	38
5.2	General Parameters	41
5.3	Capacitive Sensors Parameters	42
5.4	Button Parameters	47
5.5	Slider Parameters	51
5.6	Mapping Parameters	55
5.7	GPIO Parameters	58
6	I2C INTERFACE.....	62
6.1	I2C Write	62
6.2	I2C read	63
6.3	I2C Registers Overview	64
6.4	Status Registers	65
6.5	Control Registers	68
6.6	SPM Gateway Registers	70
6.6.1	SPM Write Sequence	71
6.6.2	SPM Read Sequence	72
6.7	NVM burn	73
7	APPLICATION INFORMATION.....	74
7.1	Typical Application Schematic	74
7.2	Example of Touch+Proximity Module	75
7.2.1	Overview	75
7.2.2	Operation	75
7.2.3	Performance	75
7.2.4	Schematics	76
7.2.5	Layout	77
8	REFERENCES	78
9	PACKAGING INFORMATION.....	79
9.1	Package Outline Drawing	79
9.2	Land Pattern	79

SX8634



Low Power, Capacitive Button and Slider Touch Controller
 (12 sensors) with Enhanced LED Drivers and Proximity Sensing

ADVANCED COMMUNICATIONS & SENSING DATASHEET

1 GENERAL DESCRIPTION

1.1 Pin Diagram

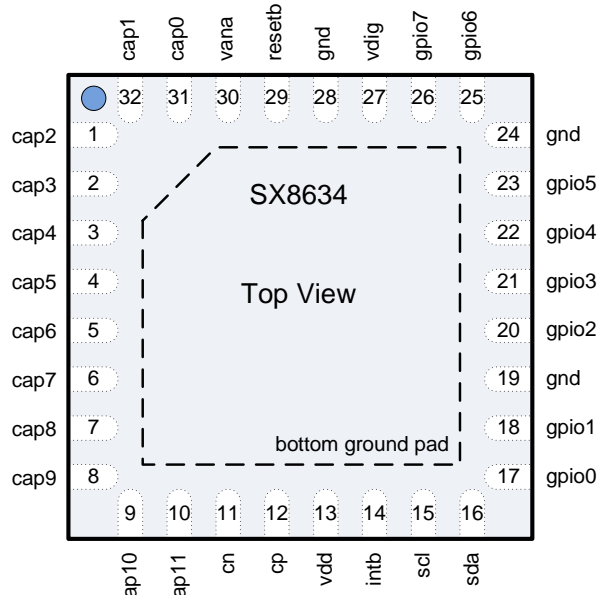
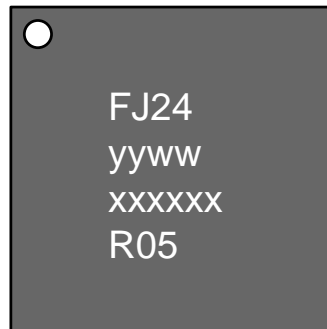

Figure 1 Pinout Diagram

1.2 Marking information



yyww = Date Code
 xxxxxx = Semtech lot number
 R05 = Semtech Code

Figure 2 Marking Information



SX8634
 Low Power, Capacitive Button and Slider Touch Controller
 (12 sensors) with Enhanced LED Drivers and Proximity Sensing

ADVANCED COMMUNICATIONS & SENSING DATASHEET

1.3 Pin Description

Number	Name	Type	Description
1	CAP2	Analog	Capacitive Sensor 2
2	CAP3	Analog	Capacitive Sensor 3
3	CAP4	Analog	Capacitive Sensor 4
4	CAP5	Analog	Capacitive Sensor 5
5	CAP6	Analog	Capacitive Sensor 6
6	CAP7	Analog	Capacitive Sensor 7
7	CAP8	Analog	Capacitive Sensor 8
8	CAP9	Analog	Capacitive Sensor 9
9	CAP10	Analog	Capacitive Sensor 10
10	CAP11	Analog	Capacitive Sensor 11
11	CN	Analog	Integration Capacitor, negative terminal (1nF between CN and CP)
12	CP	Analog	Integration Capacitor, positive terminal (1nF between CN and CP)
13	VDD	Power	Main input power supply
14	INTB	Digital Output	Interrupt, active LOW, requires pull up resistor (on host or external)
15	SCL	Digital Input	I2C Clock, requires pull up resistor (on host or external)
16	SDA	Digital Input/Output	I2C Data, requires pull up resistor (on host or external)
17	GPIO0	Digital Input/Output	General Purpose Input/Output 0
18	GPIO1	Digital Input/Output	General Purpose Input/Output 1
19	GND	Ground	Ground
20	GPIO2	Digital Input/Output	General Purpose Input/Output 2
21	GPIO3	Digital Input/Output	General Purpose Input/Output 3
22	GPIO4	Digital Input/Output	General Purpose Input/Output 4
23	GPIO5	Digital Input/Output	General Purpose Input/Output 5
24	GND	Ground	Ground
25	GPIO6	Digital Input/Output	General Purpose Input/Output 6
26	GPIO7	Digital Input/Output	General Purpose Input/Output 7
27	VDIG	Analog	Digital Core Decoupling, connect to a 100nF decoupling capacitor
28	GND	Ground	Ground
29	RESETB	Digital Input	Active Low Reset. Connect to VDD if not used.
30	VANA	Analog	Analog Core Decoupling, connect to a 100nF decoupling capacitor
31	CAP0	Analog	Capacitive Sensor 0
32	CAP1	Analog	Capacitive Sensor 1
bottom plate	GND	Ground	Exposed pad connect to ground

Table 1 Pin description

SX8634



SEMTECH

Low Power, Capacitive Button and Slider Touch Controller
 (12 sensors) with Enhanced LED Drivers and Proximity Sensing

ADVANCED COMMUNICATIONS & SENSING DATASHEET

1.4 Simplified Block Diagram

The simplified block diagram of the SX8634 is illustrated in Figure 3.

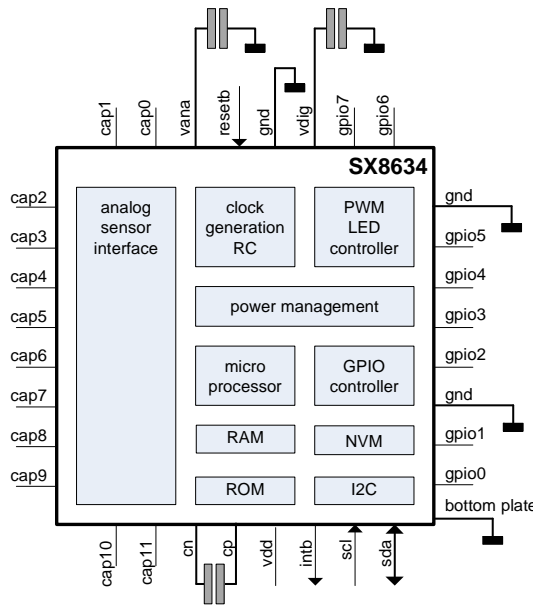

Figure 3 Simplified block diagram of the SX8634

1.5 Acronyms

ASI	Analog Sensor Interface
DCV	Digital Compensation Value
GPI	General Purpose Input
GPO	General Purpose Output
GPP	General Purpose PWM
MTP	Multiple Time Programmable
NVM	Non Volatile Memory
PWM	Pulse Width Modulation
QSM	Quick Start Memory
SPM	Shadow Parameter Memory



SX8634
 Low Power, Capacitive Button and Slider Touch Controller
 (12 sensors) with Enhanced LED Drivers and Proximity Sensing

ADVANCED COMMUNICATIONS & SENSING DATASHEET

2 ELECTRICAL CHARACTERISTICS

2.1 Absolute Maximum Ratings

Stresses above the values listed in “Absolute Maximum Ratings” may cause permanent damage to the device.

This is a stress rating only and functional operation of the device at these, or any other conditions beyond the “Recommended Operating Conditions”, is not implied. Exposure to absolute maximum rating conditions for extended periods may affect device reliability.

Parameter	Symbol	Min.	Max.	Unit
Supply Voltage	VDD	-0.5	3.9	V
Input voltage (non-supply pins)	V _{IN}	-0.5	3.9	V
Input current (non-supply pins)	I _{IN}		10	mA
Operating Junction Temperature	T _{JCT}		125	°C
Reflow temperature	T _{RE}		260	°C
Storage temperature	T _{STOR}	-50	150	°C
ESD HBM (Human Body model) ⁽ⁱ⁾	ESD _{HBM}	3		kV
Latchup ⁽ⁱⁱ⁾	I _{LU}	± 100		mA

Table 2 Absolute Maximum Ratings

(i) Tested to JEDEC standard JESD22-A114

(ii) Tested to JEDEC standard JESD78

2.2 Recommended Operating Conditions

Parameter	Symbol	Min.	Max.	Unit
Supply Voltage	VDD	2.7V	3.6	V
Supply Voltage Drop ^(iii, iv, v)	VDD _{drop}		100	mV
Supply Voltage for NVM programming	VDD	3.0V	3.6	V
Ambient Temperature Range	T _A	-40	85	°C

Table 3 Recommended Operating Conditions

(iii) Performance for 2.6V < VDD < 2.7V might be degraded.

(iv) Operation is not guaranteed below 2.6V. Should VDD briefly drop below this minimum value, then the SX8634 may require;

- a hardware reset issued by the host using the RESETB pin
- a software reset issued by the host using the I2C interface

(v) In the event the host processor is reset or undergoes a power OFF/ON cycle, it is recommended that the host also resets the SX8634 and assures that parameters are re-written into the SPM (should these differ to the parameters held in NVM).

2.3 Thermal Characteristics

Parameter	Symbol	Min.	Max.	Unit
Thermal Resistance - Junction to Ambient ^(vi)	θ _{JA}		25	°C/W

Table 4 Thermal Characteristics

(vi) Static airflow



SX8634
 Low Power, Capacitive Button and Slider Touch Controller
 (12 sensors) with Enhanced LED Drivers and Proximity Sensing

ADVANCED COMMUNICATIONS & SENSING DATASHEET

2.4 Electrical Specifications

All values are valid within the operating conditions unless otherwise specified.

Parameter	Symbol	Conditions	Min.	Typ.	Max.	Unit
Current consumption						
Active mode, average	$I_{OP,active}$	30ms scan period, 12 sensors enabled, minimum sensitivity		220	300	uA
Doze mode, average	$I_{OP,Doze}$	195ms scan period, 12 sensors enabled, minimum sensitivity		80	110	uA
Sleep	$I_{OP,sleep}$	I2C and GPI listening, sensors disabled		8	17	uA
GPIO, set as Input, RESETB, SCL, SDA						
Input logic high	V_{IH}		$0.7 \cdot V_{DD}$		$V_{DD} + 0.3V$	V
Input logic low	V_{IL}	VSS applied to GND pins	$V_{SS} - 0.3V$		0.8	V
Input leakage current	I_I	CMOS input			± 1	uA
Pull up resistor	R_{PU}	when enabled		660		k Ω
Pull down resistor	R_{PD}	when enabled		660		k Ω
GPIO set as Output, INTB, SDA						
Output logic high	V_{OH}	$I_{OH} < 4mA$	$V_{DD} - 0.4$			V
Output logic low	V_{OL}	$I_{OL,GPIO} < 12mA$ $I_{OL,SDA,INTB} < 4mA$			0.4	V
Start-up						
Power up time	t_{por}	time between rising edge VDD and rising INTB			150	ms
RESETB						
Pulse width	t_{res}		50			ns
Recommended External components						
Capacitor between VDIG, GND	C_{vdig}	type 0402, tolerance +/-50%		100		nF
Capacitor between VANA, GND	C_{vana}	type 0402, tolerance +/-50%		100		nF
Capacitor between CP, CN	C_{int}	type 0402, COG, tolerance +/-5%		1		nF
Capacitor between VDD, GND	C_{vdd}	type 0402, tolerance +/-50%		100		nF

Table 5 Electrical Specifications

SX8634



SEMTECH

Low Power, Capacitive Button and Slider Touch Controller
 (12 sensors) with Enhanced LED Drivers and Proximity Sensing

ADVANCED COMMUNICATIONS & SENSING DATASHEET

Parameter	Symbol	Conditions	Min.	Typ.	Max.	Unit
I2C Timing Specifications ⁽ⁱ⁾						
SCL clock frequency	f _{SCL}				400	KHz
SCL low period	t _{LOW}		1.3			us
SCL high period	t _{HIGH}		0.6			us
Data setup time	t _{SU;DAT}		100			ns
Data hold time	t _{HD;DAT}		0			ns
Repeated start setup time	t _{SU;STA}		0.6			us
Start condition hold time	t _{HD;STA}		0.6			us
Stop condition setup time	t _{SU;STO}		0.6			us
Bus free time between stop and start	t _{BUF}		500			us
Input glitch suppression	t _{SP}				50	ns

Table 6 I2C Timing Specification

Notes:

(i) All timing specifications, Figure 4 and Figure 5, refer to voltage levels (V_{IL}, V_{IH}, V_{OL}) defined in Table 5.

The interface complies with slave F/S mode as described by NXP: "I2C-bus specification, Rev. 03 - 19 June 2007"

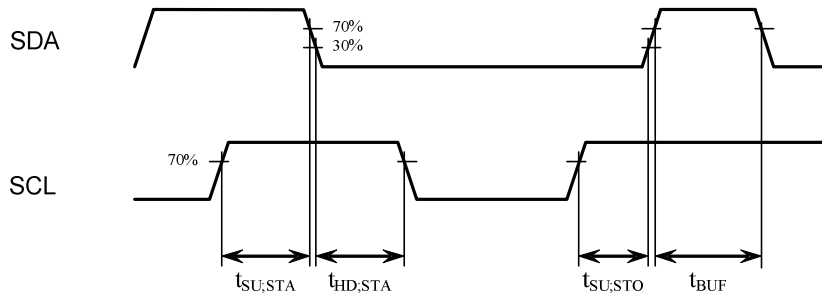

Figure 4 I2C Start and Stop timing

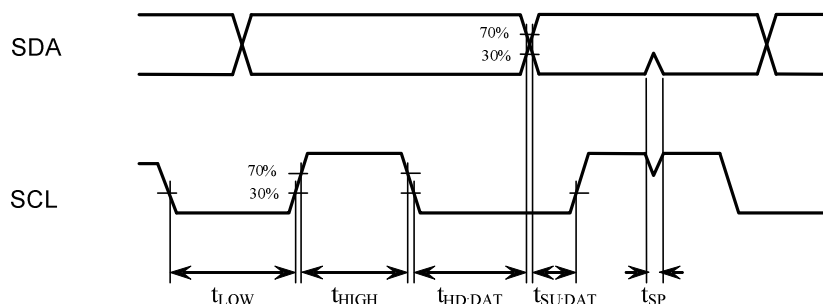

Figure 5 I2C Data timing



3 FUNCTIONAL DESCRIPTION

3.1 Quickstart Application

The SX8634 is preconfigured (Quickstart Application) for an application with 6 buttons, a slider (consisting of 6 sensors) and 8 LED drivers using logarithmic PWM fading.

Implementing a schematic based on Figure 6 will be immediately operational after powering without programming the SX8634 (even without host).

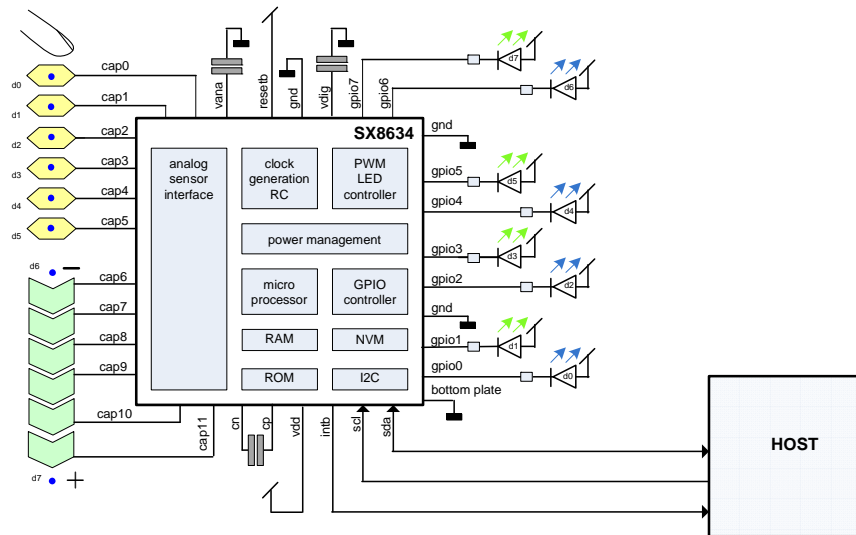

Figure 6 Quickstart Application

Touching the sensor on the CAP0 pin will enable automatically the LED connected to GPIO0. When the CAP0 sensor is released the LED on GPIO0 will slowly fade-out using smooth logarithmic fading.

All other sensors (CAP1 to CAP5) have their own LED associated on a GPIO pin showing a touch or a release.

The sensors on CAP6 to CAP11 are used in a slider configuration. A moving finger on the slider will enable the LED on GPIO6 or GPIO7 indicating the finger movement.

The sensor detection and the LED fading described above are operational without any host interaction. This is made possible using the SX8634 Autolight feature described in the following sections.

3.2 Introduction

3.2.1 General

The SX8634 is intended to be used in applications which require capacitive sensors covered by isolating overlay material and which need to detect the proximity of a finger/hand though the air. A finger approaching the capacitive sensors will change the charge that can be loaded on the sensors. The SX8634 measures the change of charge and converts that into digital values (ticks). The larger the charge on the sensors, the larger the number of ticks will be. The charge to ticks conversion is done by the SX8634 Analog Sensor Interface (ASI).

The ticks are further processed by the SX8634 and converted in a high level, easy to use information for the user's host.



SX8634

Low Power, Capacitive Button and Slider Touch Controller (12 sensors) with Enhanced LED Drivers and Proximity Sensing

ADVANCED COMMUNICATIONS & SENSING

DATASHEET

The information between SX8634 and the user's host is passed through the I2C interface with an additional interrupt signal indicating that the SX8634 has new information. For buttons this information is simply touched or released.

3.2.2 GPIOs

A second path of feedback to the user is using General Purpose Input Output (GPIO) pins. The SX8634 offers eight individual configurable GPIO pins. The GPIO can e.g. be set as a LED driver which slowly fade-in when a finger touches a button and slowly fade-out when the button is released. Fading intensity variations can be logarithmic or linear. Interval speed and initial and final light intensity can be selected by the user. The fading is done using a 256 steps PWM. The SX8634 has eight individual PWM generators, one for each GPIO pin.

The LED fading can be initiated automatically by the SX8634 by setting the SX8634 Autolight feature. A simple touch on a sensor and the corresponding LED will fade-in without any host interaction over the I2C.

In case the Autolight feature is disabled then the host will decide to start a LED fading-in period, simply by setting the GPO pin to 'high' using one I2C command. The SX8634 will then slowly fade-in the LED using the PWM autonomously.

In case the host needs to have full control of the LED intensity then the host can set the GPIO in GPP mode. The host is then able to set the PWM pulse width freely at the expense of an increased I2C occupation.

The GPIOs can be set further in the digital standard Input mode (GPI).

3.2.3 Parameters

The SX8634 has many low level built-in, fixed algorithms and procedures. To allow a lot of freedom for the user and adapt the SX8634 for different applications these algorithms and procedures can be configured with a large set of parameters which will be described in the following sections. Examples of parameters are which sensors are buttons or which sensors are parts of a slider, which GPIO is used for outputs or LEDs and which GPIO is mapped to which button.

Sensitivity and detection thresholds of the sensors are part of these parameters. Assuming that overlay material and sensors areas are identical then the sensitivities and thresholds will be the same for each sensor. In case sensors are not of the same size then sensitivities or thresholds might be chosen individually per sensor.

So a smaller size sensor can have a larger sensitivity while a big size sensor may have the lower sensitivity.

3.2.4 Configuration

During a development phase the parameters can be determined and fine tuned by the users and downloaded over the I2C in a dynamic way. The parameter set can be downloaded over the I2C by the host each time the SX8634 boots up. This allows a flexible way of setting the parameters at the expense of I2C occupation.

In case the parameters are frozen they can be programmed in Multiple Time Programmable (MTP) Non Volatile Memory (NVM) on the SX8634. The programming needs to be done once (over the I2C). The SX8634 will then boot up from the NVM and additional parameters from the host are not required anymore.

In case the host desires to overwrite the boot-up NVM parameters (partly or even complete) this can be done by additional I2C communications.



ADVANCED COMMUNICATIONS & SENSING DATASHEET

3.3 Scan Period

The basic operation Scan period of the SX8634 sensing interface can be split into three periods over time. In the first period (Sensing) the SX8634 is sensing all enabled CAP inputs, from CAP0 towards CAP11. In the second period (Processing) the SX8634 processes the sensor data, verifies and updates the GPIO and I2C status registers. In the third period (Timer) the SX8634 is set in a low power mode and waits until a new cycle starts.

Figure 7 shows the different SX8634 periods over time.

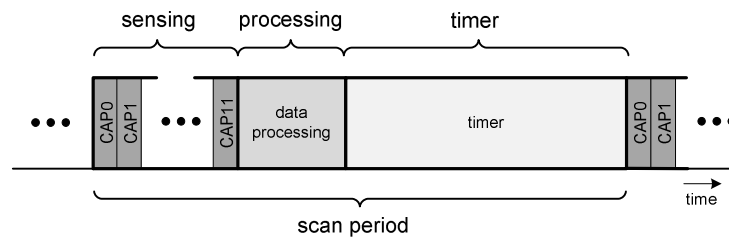

Figure 7 Scan Period

The scan period determines the minimum reaction time of the SX8634. The scan period can be configured by the host from 15ms to values larger than a second. The reaction time is defined as the interval between a touch on the sensor and the moment that the SX8634 generates the interrupt on the INTB pin. The shorter the scan period the faster the reaction time will be. Very low power consumption can be obtained by setting very long scan periods with the expense of having longer reaction times.

Important: All external events like GPIO, I2C and INTB are updated in the processing period, so once every scan period. If e.g. a GPI would change state directly after the processing period then this will be reported with a delay of one scan period later in time.

3.4 Operation modes

The SX8634 has 3 operation modes. The main difference is found in the reaction time (corresponding to the scan period) and power consumption.

Active mode offers fast scan periods. The typical reaction time is 30ms. All enabled sensors are scanned and information data is processed within this interval.

Doze mode increases the scan period time which increases the reaction time to 195ms typical and at the same time reduces the operating current.

Sleep mode turns the SX8634 OFF, except for the I2C and GPI peripheral, minimizing operating current while maintaining the power supplies. In Sleep mode the SX8634 does not do any sensor scanning.

The user can specify other scan periods for the Active and Doze mode and decide for other compromises between reaction time and power consumption.

In most applications the reaction time needs to be fast when fingers are present, but can be slow when no person uses the application. In case the SX8634 is not used for a specific time it can go from Active mode into Doze mode and power will be saved. This time-out is determined by the Passive Timer which can be configured by the user or turned OFF if not required.

SX8634



Low Power, Capacitive Button and Slider Touch Controller
 (12 sensors) with Enhanced LED Drivers and Proximity Sensing

ADVANCED COMMUNICATIONS & SENSING DATASHEET

To leave Doze mode and enter Active mode this can be done by a simple touch on any button. For some applications a single button touch might cause undesired waking up and Active mode would be entered too often. The SX8634 offers therefore a smart wake-up sequence feature in which the user needs to touch and release a correct sequence of buttons before Active mode will be entered. This is explained in more detail in the Wake-Up Sequence section.

The host can decide to force the operating mode by issuing commands over the I2C (using register CompOpMode) and take fully control of the SX8634.

The diagram in Figure 8 shows the available operation modes and the possible transitions.

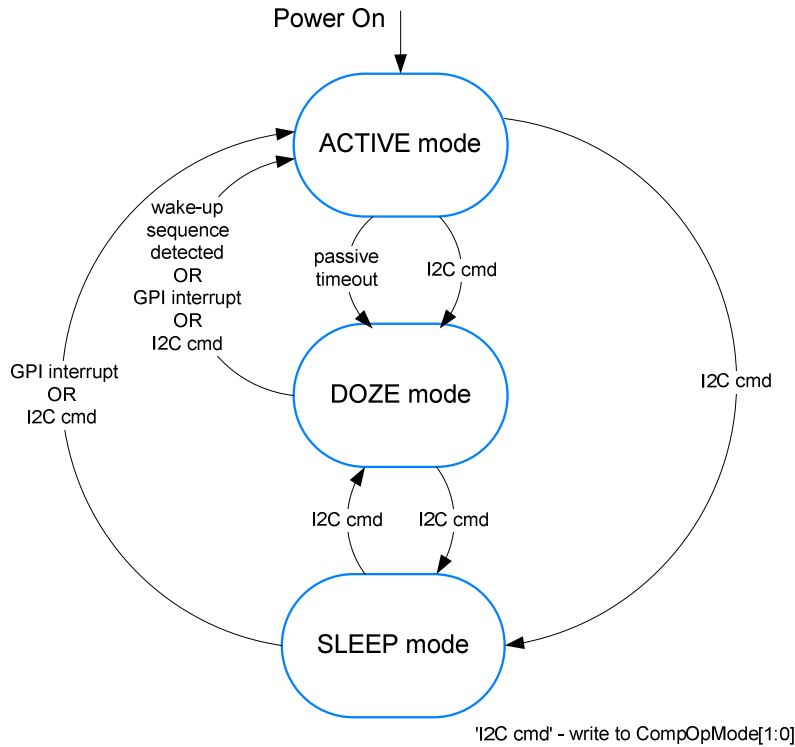

Figure 8 Operation modes



3.5 Sensors on the PCB

The capacitive sensors are relatively simple copper areas on the PCB connected to the twelve SX8634 capacitive sensor input pins (CAP0...CAP11). The sensors are covered by isolating overlay material (typically 1mm...3mm). The area of a sensor is typically one square centimeter which corresponds about to the area of a finger touching the overlay material.

The capacitive sensors can be setup as ON/OFF buttons for either touch or proximity sensing (see example Figure 9) or arranged in a slider configuration (see example Figure 10) for e.g. menu scrolling or volume control applications.

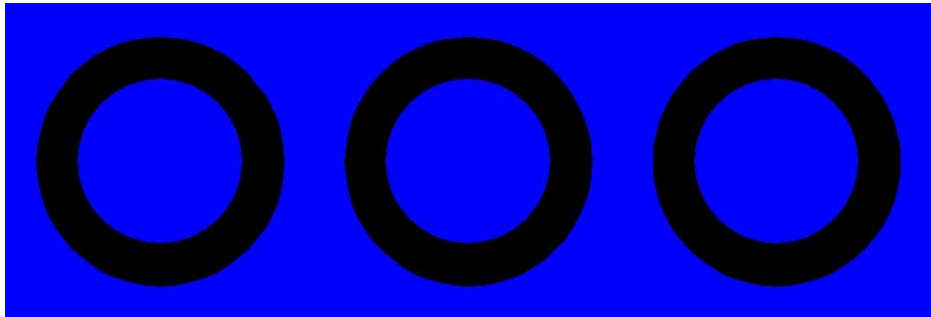

Figure 9 PCB top layer of three touch buttons sensors surrounded by a proximity sensor

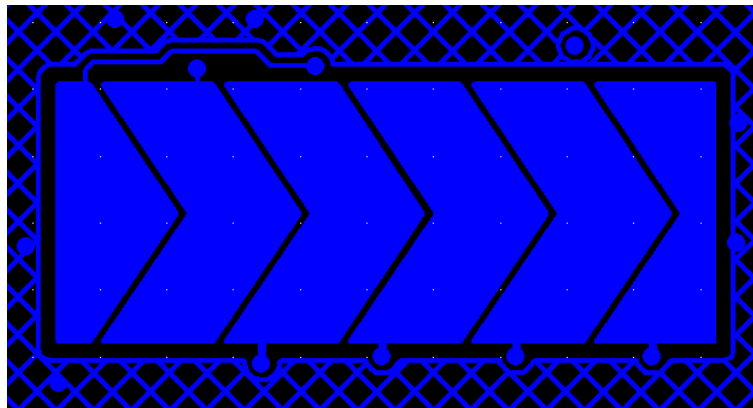

Figure 10 PCB top layer of one slider using six sensors (surrounded by ground plane)

Please refer to the layout guidelines application note [1], for more details.



Low Power, Capacitive Button and Slider Touch Controller
 (12 sensors) with Enhanced LED Drivers and Proximity Sensing

ADVANCED COMMUNICATIONS & SENSING DATASHEET

3.6 Button and Slider Information

3.6.1 Button Information

The touch buttons have two simple states (see Figure 11): ON (touched by finger) and OFF (released and no finger press).

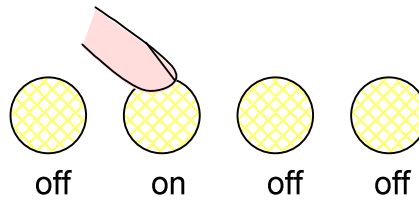

Figure 11 Buttons

A finger is detected as soon as the number of ticks from the ASI reaches a user-defined threshold plus a hysteresis.

A release is detected if the ticks from the ASI go below the threshold minus a hysteresis. The hysteresis around the threshold avoids rapid touch and release signaling during transients.

Buttons can also be used to do proximity sensing. The principle of proximity sensing operation is exactly the same as for touch buttons except that proximity sensing is done several centimeters above the overlay through the air. ON state means that finger/hand is detected by the sensor and OFF state means the finger/hand is far from the sensor.

3.6.2 Slider Information

In case sensors are arranged in a slider configuration the ON, OFF information remains available as if it would be a single sensor button.

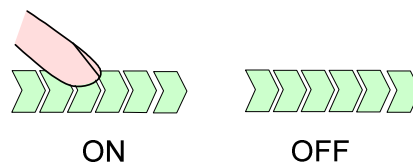

Figure 12 Slider ON, OFF

Wherever the slider is touched the information will be set to ON. If no finger is present the slider information will be OFF.

Due to the 2 dimensional character of the slider more information can be derived by processing the ticks. During a touch a finger will influence most of the time the charge on one or two sensors but never all of the sensors at the same time. Some sensor ticks will be larger than others based on the finger position. The processing algorithms can therefore determine where the finger is positioned on the slider. Interpolation between sensors increases the resolution beyond the number of sensors in the slider. The interpolation can be done already on the PCB sensor structures (analog, like the chevron slider in Figure 10) and as well by SX8634 digital processing of the ticks using center of gravity calculations.

The position of the finger on the PCB structures varies between the minimum zero and a user defined maximum (Figure 13).



Low Power, Capacitive Button and Slider Touch Controller
 (12 sensors) with Enhanced LED Drivers and Proximity Sensing

ADVANCED COMMUNICATIONS & SENSING DATASHEET

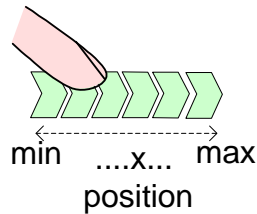

Figure 13 Slider Position

The position belonging to the minimum and associated to a sensor is defined arbitrarily. The SX8634 defines the minimum position to the sensor with the lowest CAP pin index. E.g. if CAP0 is a button (or disabled) and CAP1 to CAP7 are the sensors of the slider then the position 'zero' starts at CAP1 and the maximum is found at CAP7.

In addition to the slider position, the SX8634 allows to detect finger movements. The movement occurs if the finger position changes a certain step size between two succeeding scan periods. A very slow moving finger will not be considered as a movement as the changing position will be minor. The SX8634 allows detecting a move low (direction max to min) (see Figure 14) and a move high (direction min to max) (see Figure 15).

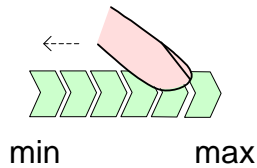

Figure 14 Slider Move Low

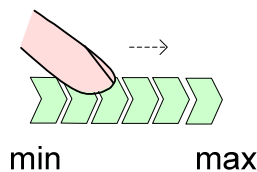

Figure 15 Slider Move High



Low Power, Capacitive Button and Slider Touch Controller
 (12 sensors) with Enhanced LED Drivers and Proximity Sensing

ADVANCED COMMUNICATIONS & SENSING DATASHEET

3.7 Analog Sensing Interface

The Analog Sensing Interface (ASI) converts the charge on the sensors into ticks which will be further digitally processed. The basic principle of the ASI will be explained in this section.

The ASI consists of a multiplexer selecting the sensor, analog switches, a reference voltage, an ADC sigma delta converter, an offset compensation DAC and an external integration capacitor (see Figure 16).

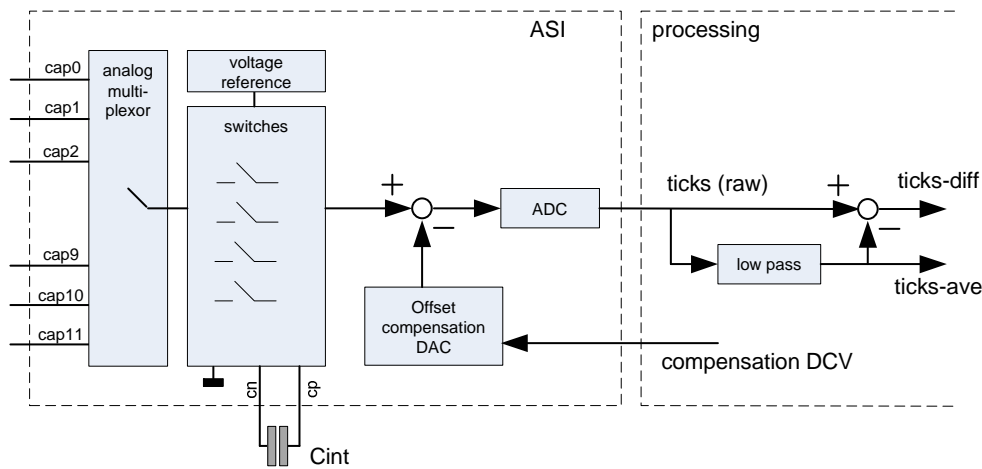

Figure 16 Analog Sensor Interface

To get the ticks representing the charge on a specific sensor the ASI will execute several steps.

The charge on a sensor cap (e.g. CAP0) will be accumulated multiple times on the external integration capacitor, Cint.

This results in an increasing voltage on Cint proportional to the capacitance on CAP0.

At this stage the offset compensation DAC is enabled. The compensation DAC generates a voltage proportional to an estimation of the external capacitance. The estimation is obtained by the offset compensation procedure executed e.g. at power-up.

The difference between the DAC output and the charge on Cint is the desired signal. In the ideal case the difference of charge will be converted to zero ticks if no finger is present and the number of ticks becomes high in case a finger is present.

The difference of charge on Cint and the DAC output will be transferred to the ADC (Sigma Delta Integrator).

After the charge transfer to the ADC the steps above will be repeated.

The larger the number the cycles are repeated the larger the signal out of the ADC with improved SNR. The sensitivity is therefore directly related to the number of cycles.

The SX8643 allows setting the sensitivity for each sensor individually in applications which have a variety of sensors sizes or different overlays or for fine-tuning performances. The optimal sensitivity is depending heavily on the final application. If the sensitivity is too low the ticks will not pass the thresholds and touch/proximity detection will not be possible. In case the sensitivity is set too large, some power will be wasted and false touch/proximity information may be output (ie for touch buttons => finger not touching yet, for proximity sensors => finger/hand not close enough).

Once the ASI has finished the first sensor, the ticks are stored and the ASI will start measuring the next sensor until all (enabled) sensors pins have been treated.

In case some sensors are disabled then these result in lower power consumption simply because the ASI is active for a shorter period and the following processing period will be shorter.



The ticks from the ASI will then be handled by the digital processing.

3.8 Offset Compensation

The capacitance at the CAP pins is determined by an intrinsic capacitance of the integrated circuit, the PCB traces, ground coupling and the sensor planes. This capacitance is relatively large and might become easily some tens of pF. This parasitic capacitance will vary only slowly over time due to environmental changes.

A finger touch is in the order of one pF. If the finger approaches the sensor this occurs typically fast.

The ASI has the difficult task to detect and distinguish a small, fast changing capacitance, from a large, slow varying capacitance. This would require a very precise, high resolution ADC and complicated, power consuming, digital processing.

The SX8634 features a 16 bit DAC which compensates for the large, slow varying capacitance already in front of the ADC. In other words the ADC converts only the desired small signal. In the ideal world the ADC will put out zero ticks even if the external capacitance is as high as 100pF.

At each power-up of the SX8634 the Digital Compensation Values (DCV) are estimated by the digital processing algorithms. The algorithm will adjust the compensation values such that zero ticks will be generated by the ADC.

Once the correct compensation values are found these will be stored and used to compensate each CAP pin.

If the SX8634 is shut down the compensation values will be lost. At a next power-up the procedure starts all over again. This assures that the SX8634 will operate under any condition. Powering up at e.g. different temperatures will not change the performance of the SX8634 and the host does not have to do anything special.

The DCVs do not need to be updated if the external conditions remain stable.

However if e.g. temperature changes this will influence the external capacitance. The ADC ticks will drift then slowly around zero values basically because of the mismatch of the compensation circuitry and the external capacitance.

In case the average value of the ticks become higher than the positive noise threshold (configurable by user) or lower than the negative threshold (configurable by user) then the SX8634 will initiate a compensation procedure and find a new set of DCVs.

Compensation procedures can as well be initiated by the SX8634 on periodic intervals. Even if the ticks remain within the positive and negative noise thresholds the compensation procedure will then estimate new sets of DCVs.

Finally the host can initiate a compensation procedure by using the I2C interface (in Active or Doze mode). This is e.g. required after the host changed the sensitivity of sensors.

SX8634



SEMTECH

Low Power, Capacitive Button and Slider Touch Controller
 (12 sensors) with Enhanced LED Drivers and Proximity Sensing

ADVANCED COMMUNICATIONS & SENSING

DATASHEET

3.9 Processing

The first processing step of the raw ticks, coming out of the ASI, is low pass filtering to obtain an estimation of the average capacitance: tick-ave (see Figure 17). This slowly varying average is important in the detection of slowly changing environmental changes.

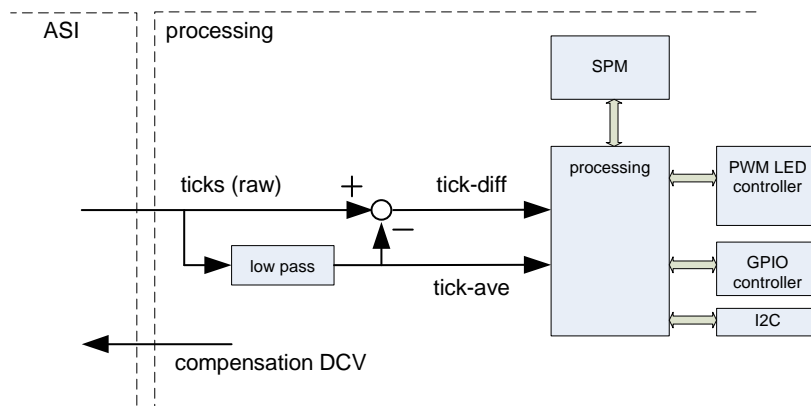

Figure 17 Processing

The difference of the tick average and the raw ticks, tick-diff, is a good estimation of rapid changing input capacitances.

The tick-diff, tick-ave and the configuration parameters in the SPM are then processed and determines the sensor information, I2C registers status and PWM control.

3.10 Configuration

Figure 18 shows the building blocks used for configuring the SX8634.

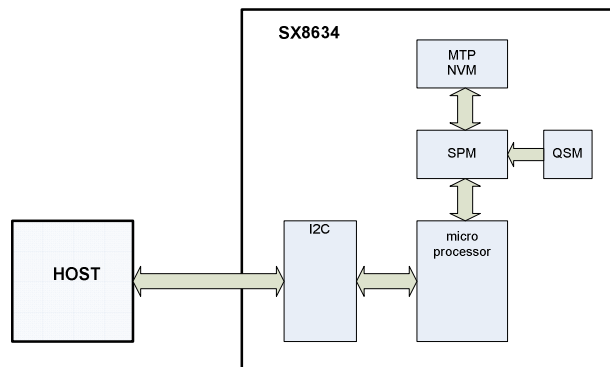

Figure 18 Configuration

The default configuration parameters of the SX8634 are stored in the Quick Start Memory (QSM). This configuration data is setup to a very common application for the SX8634 with 6 buttons and a slider. Without any programming or host interaction the SX8634 will startup in the Quick Start Application.

SX8634



Low Power, Capacitive Button and Slider Touch Controller
 (12 sensors) with Enhanced LED Drivers and Proximity Sensing

ADVANCED COMMUNICATIONS & SENSING DATASHEET

The QSM settings are fixed and can not be changed by the user.

In case the application needs different settings than the QSM settings then the SX8634 can be setup and/or programmed over the I2C interface.

The configuration parameters of the SX8634 can be stored in the Multiple Time Programmable (MTP) Non Volatile Memory (NVM). The NVM contains all those parameters that are defined and stable for the application. Examples are the number of sensors enabled, sensitivity, active and Doze scan period. The details of these parameters are described in the next chapters.

At power up the SX8634 checks if the NVM contains valid data. In that case the configuration parameter source becomes the NVM. If the NVM is empty or non-valid then the configuration source becomes the QSM. In the next step the SX8634 copies the configuration parameter source (QSM or NVM) into the Shadow Parameter Memory (SPM). The SX8634 is operational and uses the configuration parameters of the SPM.

During power down or reset event the SPM loses all content. It will automatically be reloaded (from QSM or NVM) following power up or at the end of the reset event.

The host will interface with the SX8634 through the I2C bus.

The I2C of the SX8634 consists of 16 registers. Some of these I2C registers are used to read the status and information of the button and the slider. Other I2C registers allow the host to take control of the SX8634. The host can e.g. decide to change the operation mode from Active mode to Doze mode or go into Sleep (according to Figure 8).

Two additional modes allow the host to have an access to the SPM or indirect access to the NVM. These modes are required during development, can be used in real time or in-field programming.

Figure 19 shows the Host SPM mode. In this mode the host can decide to overwrite the SPM. This is useful during the development phases of the application where the configuration parameters are not yet fully defined and as well during the operation of the application if some parameters need to be changed dynamically.

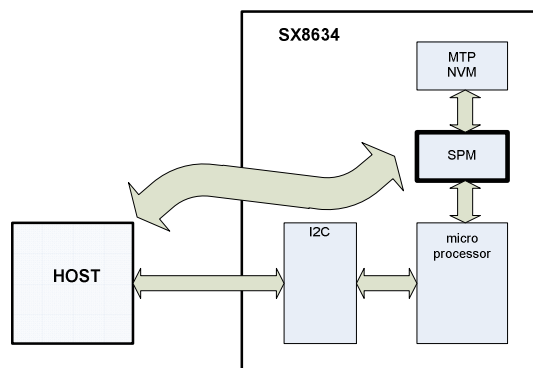

Figure 19 Host SPM mode

The content of the SPM remains valid as long as the SX8634 is powered and no reset is performed. After a power down or reset the host needs to re-write the SPM if relevant for the application.

Figure 20 shows the Host NVM mode. In this mode the host will be able to write the NVM.

SX8634



Low Power, Capacitive Button and Slider Touch Controller
 (12 sensors) with Enhanced LED Drivers and Proximity Sensing

ADVANCED COMMUNICATIONS & SENSING DATASHEET

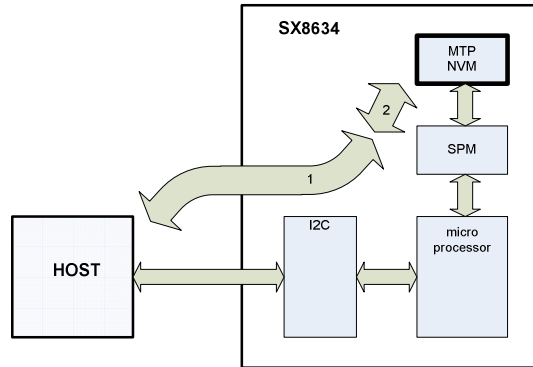

Figure 20 Host NVM mode

The writing of the host towards the NVM is not done directly but done in 2 steps (Figure 20).

In the first step the host writes to the SPM (as in Figure 19). In the second step the host signals the SX8634 to copy the SPM content into the NVM.

Initially the NVM memory is empty and it is required to determine a valid parameter set for the application. This can be done during the development phase using dedicated evaluation hardware representing the final application. This development phase uses probably initially the host SPM mode which allows faster iterations.

Once the parameter set is determined this can be written to the NVM over the I2C using the 2 steps approach by the host or a dedicated programmer for large volumes production (as described in the paragraphs 6.6 and 6.7).

3.11 Power Management

The SX8634 uses on-chip voltage regulators which are controlled by the on-chip microprocessor. The regulators need to be stabilized with an external capacitor between VANA and ground and between VDIG and ground (see Table 5). Both regulators are designed to only drive the SX8634 internal circuitry and must not be loaded externally.

3.12 Clock Circuitry

The SX8634 has its own internal clock generation circuitry that does not require any external components. The clock circuitry is optimized for low power operation and is controlled by the on-chip microprocessor. The typical operating frequency of the oscillating core is 16.7MHz from which all other lower frequencies are derived.

3.13 I2C interface

The I2C interface allows the communication between the host and the SX8634.

The I2C slave implemented on the SX8634 is compliant with the standard (100kb/s) and fast mode (400kb/s). The default SX8634 I2C address equals 0b010 1011. A different I2C address can be programmed by the user in the NVM.



Low Power, Capacitive Button and Slider Touch Controller
 (12 sensors) with Enhanced LED Drivers and Proximity Sensing

ADVANCED COMMUNICATIONS & SENSING DATASHEET

3.14 Reset

The reset can be performed by 3 sources:

- power up,
- RESETB pin,
- software reset.

3.14.1 Power up

During power up the INTB is kept low. Once the power up sequence is terminated the INTB is released autonomously. The SX8634 is then ready for operation.

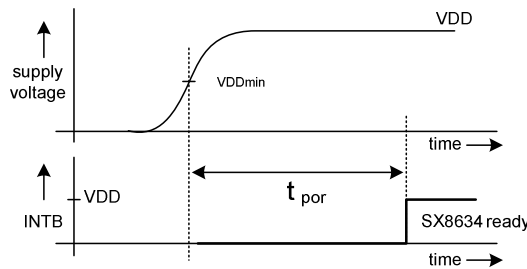

Figure 21 Power Up vs. INTB

During the power on period the SX8634 stabilizes the internal regulators, RC clocks and the firmware initializes all registers.

During the power up the SX8634 is not accessible and I2C communications are forbidden. As soon as the INTB rises the SX8634 will be ready for I2C communication.

3.14.2 RESETB

When RESETB is driven low the SX8634 will reset and start the power up sequence as soon as RESETB is driven high or pulled high.

In case the user does not require a hardware reset control pin then the RESETB pin can be connected to VDD.

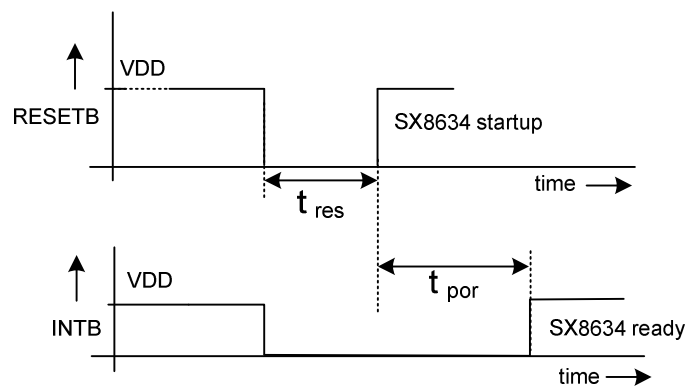

Figure 22 Hardware Reset

SX8634



Low Power, Capacitive Button and Slider Touch Controller
 (12 sensors) with Enhanced LED Drivers and Proximity Sensing

ADVANCED COMMUNICATIONS & SENSING DATASHEET

3.14.3 Software Reset

To perform a software reset the host needs to write 0xDE followed by 0x00 at the SoftReset register at address 0xB1.

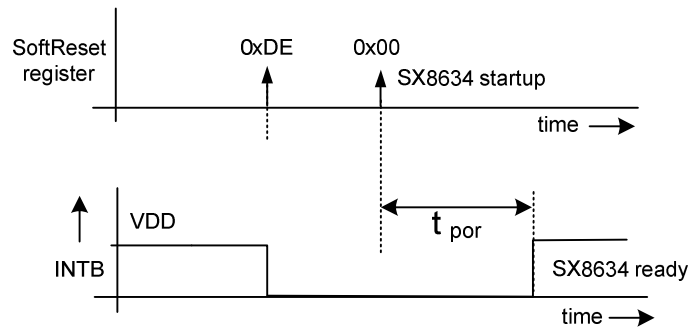

Figure 23 Software Reset



Low Power, Capacitive Button and Slider Touch Controller
 (12 sensors) with Enhanced LED Drivers and Proximity Sensing

ADVANCED COMMUNICATIONS & SENSING DATASHEET

3.15 Interrupt

3.15.1 Power up

During power up the INTB is kept low. Once the power up sequence is terminated the INTB is released autonomously. The SX8634 is then ready for operation.

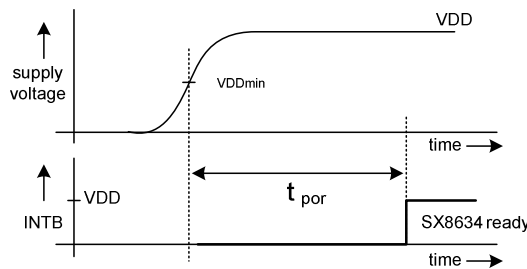

Figure 24 Power Up vs. INTB

During the power on period the SX8634 stabilizes the internal regulators, RC clocks and the firmware initializes all registers.

During the power up the SX8634 is not accessible and I2C communications are forbidden. As soon as the INTB rises the SX8634 will be ready for I2C communication.

3.15.2 Assertion

INTB is updated in Active or Doze mode once every scan period.

The INTB will be asserted: at the following events:

- if a Button event occurred (touch or release if enabled). I2C registers CapStatMsb and CapStatLsb show the detailed status of the Buttons,
- if a Slider event occurred (touch, release, move high, move low or position change). I2C registers CapStatMsb, SldPosMsb and SldPosLsb show the detailed status of the Slider,
- if a GPI edge occurred (rising or falling if enabled). I2C register GpiStat shows the detailed status of the GPI pins,
- when actually entering Active or Doze mode either through automatic wakeup or via host request (may be delayed by 1 scan period). I2C register CompOpmode shows the current operation mode,
- once compensation procedure is completed either through automatic trigger or via host request (may be delayed by 1 scan period),
- once SPM write is effective (may be delayed by 1 scan period),
- once NVM burn procedure is completed (may be delayed by 1 scan period),
- during reset (power up, hardware RESETB, software reset).

3.15.3 Clearing

INTB is updated in Active or Doze mode once every scan period.

The clearing of the INTB is done as soon as the host performs a read to the IrqSrc I2C register or reset is completed

SX8634



Low Power, Capacitive Button and Slider Touch Controller
 (12 sensors) with Enhanced LED Drivers and Proximity Sensing

ADVANCED COMMUNICATIONS & SENSING DATASHEET

3.15.4 Example

A typical example of the assertion and clearing of the INTB and the I2C communication is shown in Figure 25.

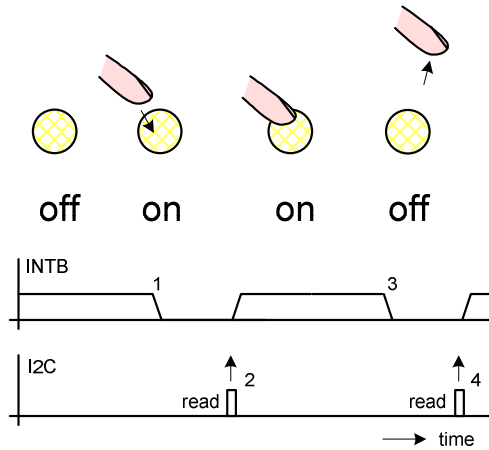

Figure 25 Interrupt and I2C

When a button is touched the SX8634 will assert the interrupt (1). The host will read the IrqSrc information over the I2C and this clears the interrupt (2).

If the finger releases the button the interrupt will be asserted (3). The host reading the IrqSrc information will clear the interrupt (4).

In case the host does not react to an interrupt this results in a missing touch.

3.16 General Purpose Input and Outputs

3.16.1 Introduction and Definitions

The SX8634 offers eight General Purpose Input and Outputs (GPIO) pins which can be configured in any of these modes:

- GPI (General Purpose Input)
- GPP (General Purpose PWM)
- GPO (General Purpose Output)

Each of these modes is described in more details in the following sections.

The polarity of the GPP and GPO pins is defined as in figure below, driving an LED as example. It has to be set accordingly in SPM parameter GpioPolarity.

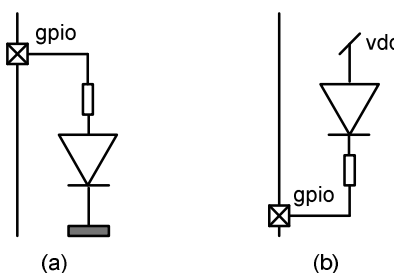

Figure 26 Polarity definition, (a) normal, (b) inverted

SX8634



Low Power, Capacitive Button and Slider Touch Controller
 (12 sensors) with Enhanced LED Drivers and Proximity Sensing

ADVANCED COMMUNICATIONS & SENSING DATASHEET

The PWM blocks used in GPP and GPO modes are 8-bits based and clocked at 2MHz typ. hence offering 256 selectable pulse width values with a granularity of 128us typ.

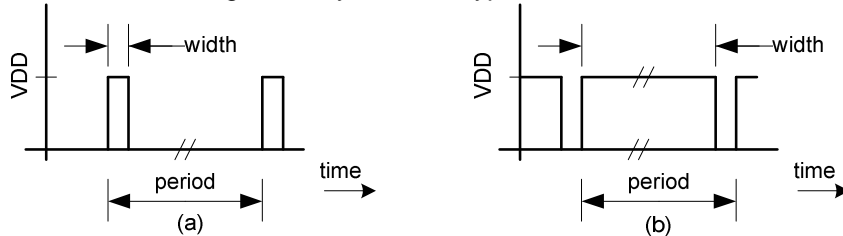

Figure 27 PWM definition, (a) small pulse width, (b) large pulse width

3.16.2 GPI

GPIOs configured as GPI will operate as digital inputs with standard low and high logic levels. Optional pull-up/down and debounce can be enabled. Each GPI is individually edge programmable for INTB generation which will also exit Sleep/Doze mode if relevant.

SPM/I2C parameters applicable in GPI mode are listed in table below. Please refer to the relevant SPM/I2C parameters sections for more details.

		GPI
SPM	GpioMode	X
	GpioPullUpDown	X
	GpioInterrupt	X
	GpioDebounce	X
I2C	IrqSrc[4]	X
	GpiStat	X

Table 7 SPM/I2C Parameters Applicable in GPI Mode

3.16.3 GPP

GPIOs configured as GPP will operate as PWM outputs directly controlled by the host. A typical application is LED dimming.

Typical GPP operation is illustrated in figure below.

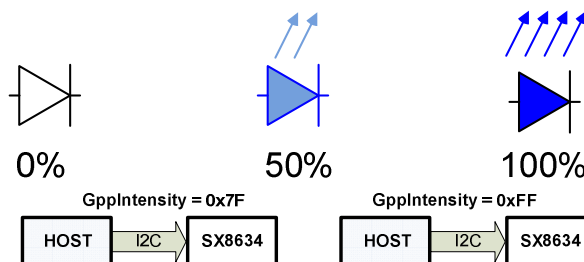

Figure 28 LED control in GPP mode

SPM/I2C parameters applicable in GPP mode are listed in table below. Please refer to the relevant SPM/I2C parameters sections for more details.



Low Power, Capacitive Button and Slider Touch Controller
 (12 sensors) with Enhanced LED Drivers and Proximity Sensing

ADVANCED COMMUNICATIONS & SENSING DATASHEET

		GPP
SPM	GpioMode	X
	GpioOutPwrUp	X ¹
	GpioPolarity	X
	GpioIntensityOn	X ¹
	GpioIntensityOff	X ¹
	GpioFunction	X
I2C	GppPinId	X
	GppIntensity	X ¹

¹ At power up, GppIntensity of each GPP pin is initialized with GpioIntensityOn or GpioIntensityOff depending on GpioOutPwrUp corresponding bits value.

Table 8 SPM/I2C Parameters Applicable in GPP Mode

3.16.4 GPO

GPIOs configured as GPO will operate as digital outputs which can generate both standard low/high logic levels and PWM low/high duty cycles levels. Typical application is LED ON/OFF control.

Transitions between ON and OFF states can be triggered either automatically in Autolight mode or manually by the host. This is illustrated in figures below.

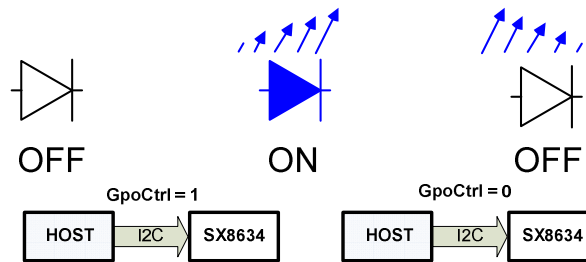

Figure 29 LED Control in GPO mode, Autolight OFF

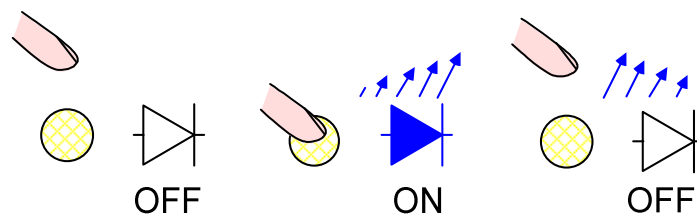

Figure 30 LED Control in GPO mode, Autolight ON (mapped to Button)

Additionally these transitions can be configured to be done with or without fading following a logarithmic or linear function. This is illustrated in figures below.

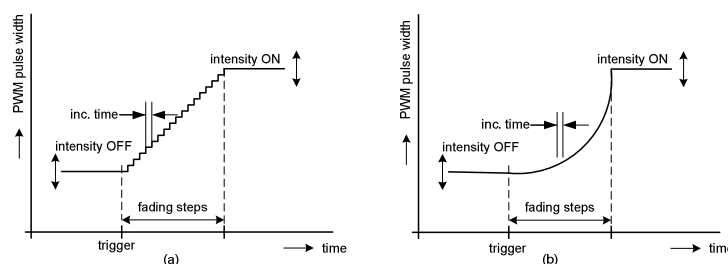

Figure 31 GPO ON transition (LED fade in), normal polarity, (a) linear, (b) logarithmic



Low Power, Capacitive Button and Slider Touch Controller
 (12 sensors) with Enhanced LED Drivers and Proximity Sensing

ADVANCED COMMUNICATIONS & SENSING

DATASHEET

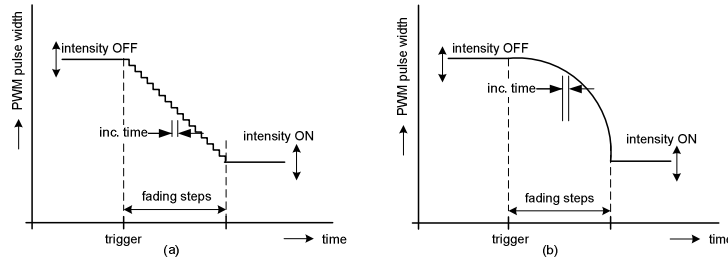

Figure 32 GPO ON transition (LED fade in), inverted polarity, (a) linear, (b) logarithmic

The fading out (e.g. after a button is released) is identical to the fading in but an additional off delay can be added before the fading starts (Figure 33 and Figure 34).

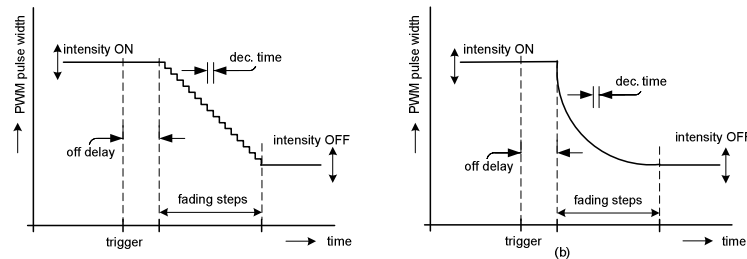

Figure 33 GPO OFF transition (LED fade out), normal polarity, (a) linear, (b) logarithmic

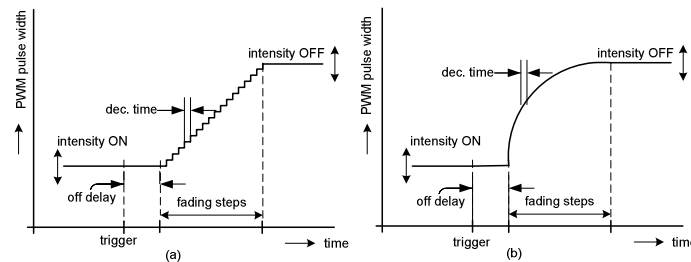

Figure 34 GPO OFF transition (LED fade out), inverted polarity, (a) linear, (b) logarithmic

Please note that standard high/low logic signals are just a specific case of GPO mode and can also be generated simply by setting inc/dec time to 0 (ie OFF) and programming intensity OFF/ON to 0x00 and 0xFF.

SX8634



SEMTECH

Low Power, Capacitive Button and Slider Touch Controller
 (12 sensors) with Enhanced LED Drivers and Proximity Sensing

ADVANCED COMMUNICATIONS & SENSING DATASHEET

SPM/I2C parameters applicable in GPO mode are listed in table below.

		GPO
SPM	GpioMode	X
	GpioOutPwrUp	X ¹
	GpioAutoligh	X
	GpioPolarity	X
	GpioIntensityOn	X
	GpioIntensityOff	X
	GpioFunction	X
	GpioIncFactor	X
	GpioDecFactor	X
	GpioIncTime	X
	GpioDecTime	X
	GpioOffDelay	X
	I2C	GpoCtrl

¹ Only if Autolight is OFF, else must be left to 0 (default value)

² Only if Autolight is OFF, else ignored

Table 9 SPM/I2C Parameters Applicable in GPO Mode



SX8634
 Low Power, Capacitive Button and Slider Touch Controller
 (12 sensors) with Enhanced LED Drivers and Proximity Sensing

ADVANCED COMMUNICATIONS & SENSING DATASHEET

3.16.5 Intensity index vs PWM pulse width

Tables below are used to convert all intensity indexes parameters GpioIntensityOff, GpioIntensityOn and GppIntensity but also to generate fading in GPO mode
 During fading in(out), the index is automatically incremented(decremented) at every Inc(Dec)Time x Inc(Dec)Factor until it reaches the programmed GpioIntensityOn(Off) value.

Index	Lin/Log	Index	Lin/Log	Index	Lin/Log	Index	Lin/Log	Index	Lin/Log	Index	Lin/Log	Index	Lin/Log	Index	Lin/Log
0	0/0	32	33/5	64	65/12	96	97/26	128	129/48	160	161/81	192	193/125	224	225/184
1	2/0	33	34/5	65	66/13	97	98/27	129	130/49	161	162/82	193	194/127	225	226/186
2	3/0	34	35/5	66	67/13	98	99/27	130	131/50	162	163/83	194	195/129	226	227/188
3	4/0	35	36/5	67	68/13	99	100/28	131	132/51	163	164/84	195	196/130	227	228/190
4	5/0	36	37/5	68	69/14	100	101/29	132	133/52	164	165/86	196	197/132	228	229/192
5	6/2	37	38/6	69	70/14	101	102/29	133	134/53	165	166/87	197	198/133	229	230/194
6	7/2	38	39/6	70	71/14	102	103/30	134	135/54	166	167/88	198	199/135	230	231/197
7	8/2	39	40/6	71	72/15	103	104/30	135	136/55	167	168/89	199	200/137	231	232/199
8	9/2	40	41/6	72	73/15	104	105/31	136	137/55	168	169/91	200	201/139	232	233/201
9	10/2	41	42/6	73	74/15	105	106/32	137	138/56	169	170/92	201	202/140	233	234/203
10	11/2	42	43/7	74	75/16	106	107/32	138	139/57	170	171/93	202	203/142	234	235/205
11	12/2	43	44/7	75	76/16	107	108/33	139	140/58	171	172/95	203	204/144	235	236/208
12	13/2	44	45/7	76	77/16	108	109/33	140	141/59	172	173/96	204	205/146	236	237/210
13	14/2	45	46/7	77	78/17	109	110/34	141	142/60	173	174/97	205	206/147	237	238/212
14	15/3	46	47/7	78	79/17	110	111/35	142	143/61	174	175/99	206	207/149	238	239/215
15	16/3	47	48/8	79	80/18	111	112/35	143	144/62	175	176/100	207	208/151	239	240/217
16	17/3	48	49/8	80	81/18	112	113/36	144	145/63	176	177/101	208	209/153	240	241/219
17	18/3	49	50/8	81	82/19	113	114/37	145	146/64	177	178/103	209	210/155	241	242/221
18	19/3	50	51/8	82	83/19	114	115/38	146	147/65	178	179/104	210	211/156	242	243/224
19	20/3	51	52/9	83	84/20	115	116/38	147	148/66	179	180/106	211	212/158	243	244/226
20	21/3	52	53/9	84	85/20	116	117/39	148	149/67	180	181/107	212	213/160	244	245/229
21	22/3	53	54/9	85	86/21	117	118/40	149	150/68	181	182/109	213	214/162	245	246/231
22	23/3	54	55/9	86	87/21	118	119/40	150	151/69	182	183/110	214	215/164	246	247/233
23	24/4	55	56/10	87	88/22	119	120/41	151	152/71	183	184/111	215	216/166	247	248/236
24	25/4	56	57/10	88	89/22	120	121/42	152	153/72	184	185/113	216	217/168	248	249/238
25	26/4	57	58/10	89	90/23	121	122/43	153	154/73	185	186/114	217	218/170	249	250/241
26	27/4	58	59/10	90	91/23	122	123/44	154	155/74	186	187/116	218	219/172	250	251/243
27	28/4	59	60/11	91	92/24	123	124/44	155	156/75	187	188/117	219	220/174	251	252/246
28	29/4	60	61/11	92	93/24	124	125/45	156	157/76	188	189/119	220	221/176	252	253/248
29	30/4	61	62/11	93	94/25	125	126/46	157	158/77	189	190/121	221	222/178	253	254/251
30	31/4	62	63/12	94	95/25	126	127/47	158	159/78	190	191/122	222	223/180	254	255/253
31	32/5	63	64/12	95	96/26	127	128/48	159	160/80	191	192/124	223	224/182	255	256/256

Table 10 Intensity index vs. PWM pulse width (normal polarity)

Index	Lin/Log	Index	Lin/Log	Index	Lin/Log	Index	Lin/Log	Index	Lin/Log	Index	Lin/Log	Index	Lin/Log	Index	Lin/Log
0	256/256	32	224/251	64	192/244	96	160/230	128	128/208	160	96/175	192	64/131	224	32/72
1	255/256	33	223/251	65	191/243	97	159/229	129	127/207	161	95/174	193	63/129	225	31/70
2	254/256	34	222/251	66	190/243	98	158/229	130	126/206	162	94/173	194	62/127	226	30/68
3	253/256	35	221/251	67	189/243	99	157/228	131	125/205	163	93/172	195	61/126	227	29/66
4	252/256	36	220/251	68	188/242	100	156/227	132	124/204	164	92/170	196	60/124	228	28/64
5	251/254	37	219/250	69	187/242	101	155/227	133	123/203	165	91/169	197	59/123	229	27/62
6	250/254	38	218/250	70	186/242	102	154/226	134	122/202	166	90/168	198	58/121	230	26/59
7	249/254	39	217/250	71	185/241	103	153/226	135	121/201	167	89/167	199	57/119	231	25/57
8	248/254	40	216/250	72	184/241	104	152/225	136	120/201	168	88/165	200	56/117	232	24/55
9	247/254	41	215/250	73	183/241	105	151/224	137	119/200	169	87/164	201	55/116	233	23/53
10	246/254	42	214/249	74	182/240	106	150/224	138	118/199	170	86/163	202	54/114	234	22/50
11	245/254	43	213/249	75	181/240	107	149/223	139	117/198	171	85/161	203	53/112	235	21/48
12	244/254	44	212/249	76	180/240	108	148/223	140	116/197	172	84/160	204	52/110	236	20/46
13	243/254	45	211/249	77	179/239	109	147/222	141	115/196	173	83/159	205	51/109	237	19/44
14	242/253	46	210/249	78	178/239	110	146/221	142	114/195	174	82/157	206	50/107	238	18/41
15	241/253	47	209/248	79	177/238	111	145/221	143	113/194	175	81/156	207	49/105	239	17/39
16	240/253	48	208/248	80	176/238	112	144/220	144	112/193	176	80/155	208	48/103	240	16/37
17	239/253	49	207/248	81	175/237	113	143/219	145	111/192	177	79/153	209	47/101	241	15/35
18	238/253	50	206/248	82	174/237	114	142/218	146	110/191	178	78/152	210	46/100	242	14/32
19	237/253	51	205/247	83	173/236	115	141/218	147	109/190	179	77/150	211	45/98	243	13/30
20	236/253	52	204/247	84	172/236	116	140/217	148	108/189	180	76/149	212	44/96	244	12/27
21	235/253	53	203/247	85	171/235	117	139/216	149	107/188	181	75/147	213	43/94	245	11/25
22	234/253	54	202/247	86	170/235	118	138/216	150	106/187	182	74/146	214	42/92	246	10/23
23	233/252	55	201/246	87	169/234	119	137/215	151	105/185	183	73/145	215	41/90	247	9/20
24	232/252	56	200/246	88	168/234	120	136/214	152	104/184	184	72/143	216	40/88	248	8/18
25	231/252	57	199/246	89	167/233	121	135/213	153	103/183	185	71/142	217	39/86	249	7/15
26	230/252	58	198/246	90	166/233	122	134/212	154	102/182	186	70/140	218	38/84	250	6/13
27	229/252	59	197/245	91	165/232	123	133/212	155	101/181	187	69/139	219	37/82	251	5/10
28	228/252	60	196/245	92	164/232	124	132/211	156	100/180	188	68/137	220	36/80	252	4/8
29	227/252	61	195/245	93	163/231	125	131/210	157	99/179	189	67/135	221	35/78	253	3/5
30	226/252	62	194/244	94	162/231	126	130/209	158	98/178	190	66/134	222	34/76	254	2/3
31	225/251	63	193/244	95	161/230	127	129/208	159	97/176	191	65/132	223	33/74	255	0/0

Table 11 Intensity index vs. PWM pulse width (inverted polarity)

Recommended/default settings are inverted polarity (to take advantage from high sink current capability) and logarithmic mode (due to the non-linear response of the human eye).



SEMTECH

Low Power, Capacitive Button and Slider Touch Controller
(12 sensors) with Enhanced LED Drivers and Proximity Sensing

SX8634

ADVANCED COMMUNICATIONS & SENSING

DATASHEET

3.17 Smart Wake Up

The SX8634 offers a smart wake up mechanism (up to 6 keys) which allows waking-up from the Doze low power mode to the Active mode in a secure/controlled way and not by any unintentional sensor activation.

Until the full correct wake-up sequence is entered, the SX8634 will remain in Doze mode. Any wrong key implies the whole sequence to be entered again.

Please note that each key touch must be followed by a release to be validated.

Hence if a proximity sensor and a touch button part of the wake-up sequence are interleaved on the PCB (ie if you cannot touch the button without triggering proximity detection) the smart wake up feature cannot be used since the proximity sensor is not "released" before the buttons are touched. In this case the smart wakeup sequence must be turned OFF.

The smart wake-up mechanism can also be disabled which implies that Doze mode can hence only be exited from GPI or I2C command.



Low Power, Capacitive Button and Slider Touch Controller
 (12 sensors) with Enhanced LED Drivers and Proximity Sensing

ADVANCED COMMUNICATIONS & SENSING DATASHEET

4 PIN DESCRIPTIONS

4.1 Introduction

This chapter describes briefly the pins of the SX8634, the way the pins are protected, if the pins are analog, digital, require pull up or pull down resistors and show control signals if these are available.

4.2 ASI pins

CAP0, CAP1, ..., CAP11

The capacitance sensor pins (CAP0, CAP1, ..., CAP11) are connected directly to the ASI circuitry which converts the sensed capacitance into digital values.

The capacitance sensor pins which are not used should be left open.

The enabled CAP pins need be connected directly to the sensors without significant resistance (typical below some ohms, connection vias are allowed).

The capacitance sensor pins are protected to VANA and GROUND.

Figure 35 shows the simplified diagram of the CAP0, CAP1, ..., CAP11 pins.

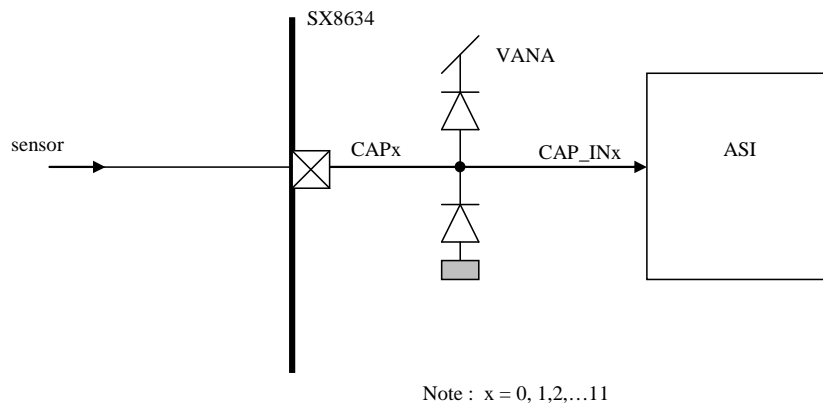

Figure 35 Simplified diagram of CAP0, CAP1, ..., CAP11

CN, CP

The CN and the CP pins are connected to the ASI circuitry. A 1nF sampling capacitor between CP and CN needs to be placed as close as possible to the SX8634.

The CN and CP are protected to VANA and GROUND.

Figure 36 shows the simplified diagram of the CN and CP pins.

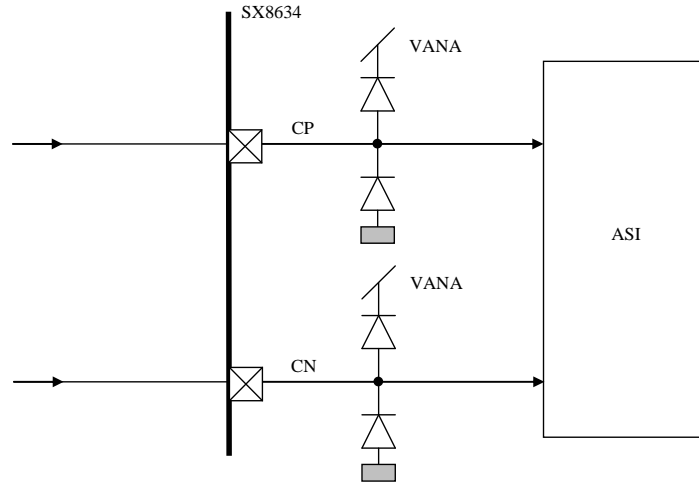

Figure 36 Simplified diagram of CN and CP

4.3 Host interface pins

The host interface consists of the interrupt pin INTB, a reset pin RESETB and the standard I2C pins: SCL and SDA.

INTB

The INTB pin is an open drain output that requires an external pull-up resistor (1..10 kOhm). The INTB pin is protected to VDD using dedicated devices. The INTB pin has diode protected to GROUND.

Figure 37 shows a simplified diagram of the INTB pin.

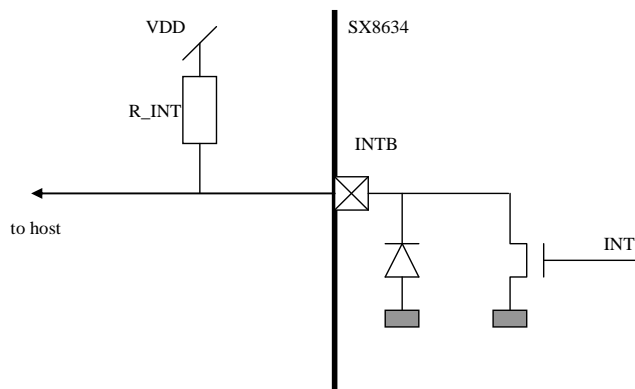

Figure 37 Simplified diagram of INTB

SX8634



Low Power, Capacitive Button and Slider Touch Controller
 (12 sensors) with Enhanced LED Drivers and Proximity Sensing

ADVANCED COMMUNICATIONS & SENSING DATASHEET

SCL

The SCL pin is a high impedance input pin. The SCL pin is protected to VDD, using dedicated devices, in order to conform to standard I2C slave specifications. The SCL pin has diode protected to GROUND. An external pull-up resistor (1..10 kOhm) is required on this pin.

Figure 38 shows the simplified diagram of the SCL pin.

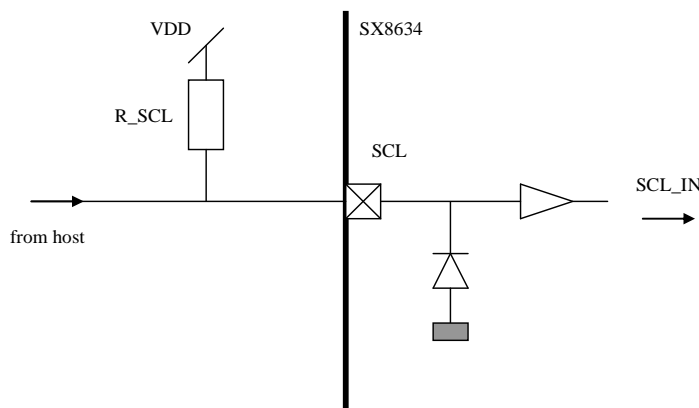

Figure 38 Simplified diagram of SCL

SDA

SDA is an IO pin that can be used as an open drain output pin with external pull-up resistor or as a high impedance input pin. The SDA IO pin is protected to VDD, using dedicated devices, in order to conform to standard I2C slave specifications. The SDA pin has diode protected to GROUND.

An external pull-up resistor (1..10 kOhm) is required on this pin.

Figure 39 shows the simplified diagram of the SDA pin.

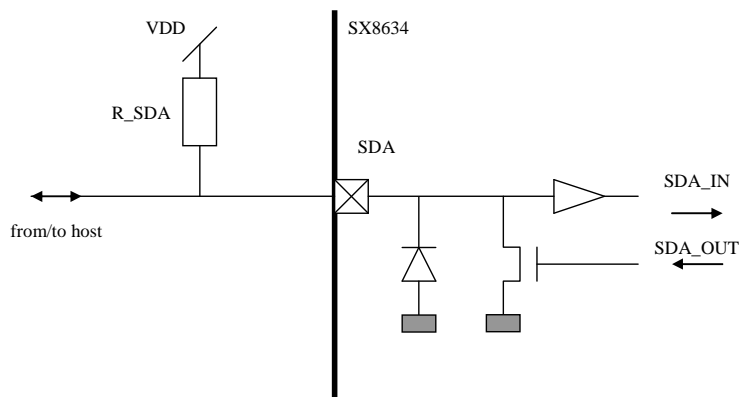

Figure 39 Simplified diagram of SDA



SX8634

Low Power, Capacitive Button and Slider Touch Controller
 (12 sensors) with Enhanced LED Drivers and Proximity Sensing

ADVANCED COMMUNICATIONS & SENSING DATASHEET

RESETB

The RESETB pin is a high impedance input pin. The RESETB pin is protected to VDD using dedicated devices. The RESETB pin has diode protected to GROUND.

Figure 40 shows the simplified diagram of the RESETB pin controlled by the host.

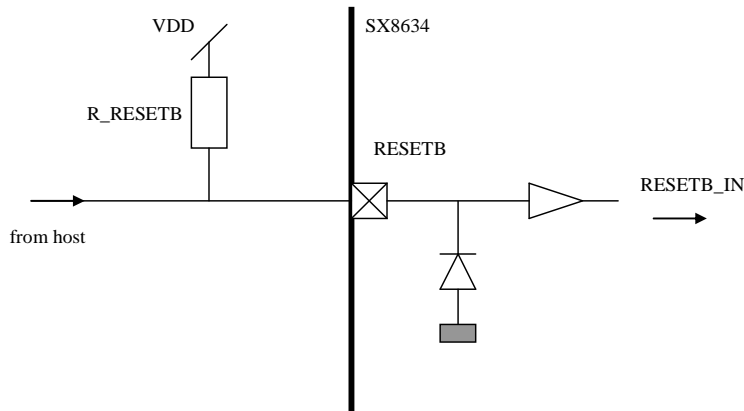

Figure 40 Simplified diagram of RESETB controlled by host

Figure 41 shows the RESETB without host control.

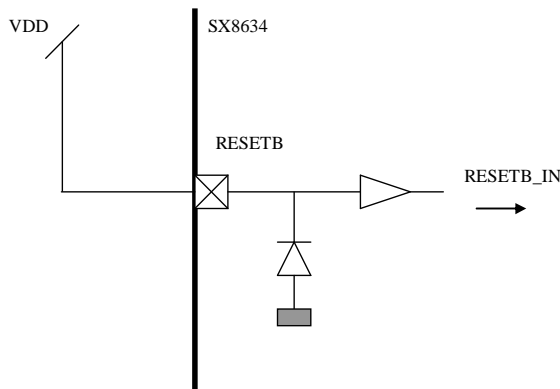

Figure 41 Simplified diagram of RESETB without host control

SX8634



Low Power, Capacitive Button and Slider Touch Controller
 (12 sensors) with Enhanced LED Drivers and Proximity Sensing

ADVANCED COMMUNICATIONS & SENSING DATASHEET

4.4 Power management pins

The power management pins consist of the Power, Ground and Regulator pins.

VDD

VDD is a power pin and is the main power supply for the SX8634.
 VDD has protection to GROUND.

Figure 42 shows a simplified diagram of the VDD pin.

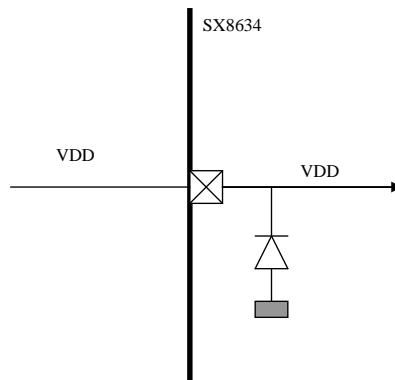

Figure 42 Simplified diagram of VDD

GND

The SX8634 has four ground pins all named GND. These pins and the package center pad need to be connected to ground potential.

The GND has protection to VDD.

Figure 43 shows a simplified diagram of the GND pin.

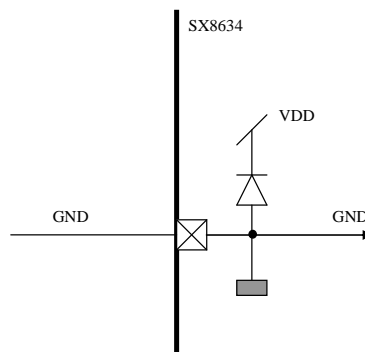

Figure 43 Simplified diagram of GND

SX8634



Low Power, Capacitive Button and Slider Touch Controller
 (12 sensors) with Enhanced LED Drivers and Proximity Sensing

ADVANCED COMMUNICATIONS & SENSING DATASHEET

VANA, VDIG

The SX8634 has on-chip regulators for internal use (pins VANA and VDIG).

VANA and VDIG have protection to VDD and to GND.

The output of the regulators needs to be de-coupled with a small 100nF capacitor to ground.

Figure 44 shows a simplified diagram of the VANA and VDIG pin.

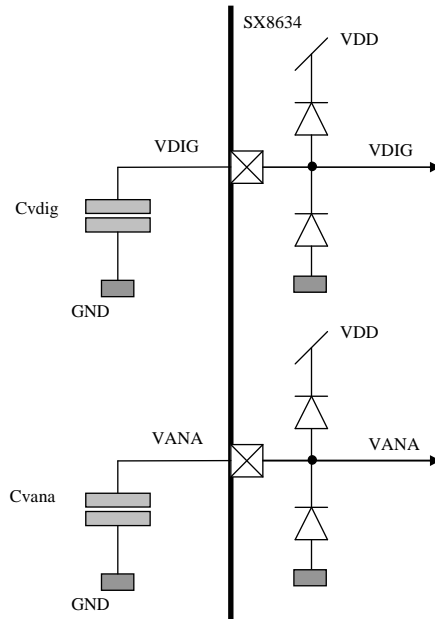

Figure 44 Simplified diagram of VANA and VDIG

4.5 General purpose IO pins

The SX8634 has 8 General purpose input/output (GPIO) pins.

All the GPIO pins have protection to VDD and GND.

The GPIO pins can be configured as GPI, GPO or GPP.

Figure 45 shows a simplified diagram of the GPIO pins.

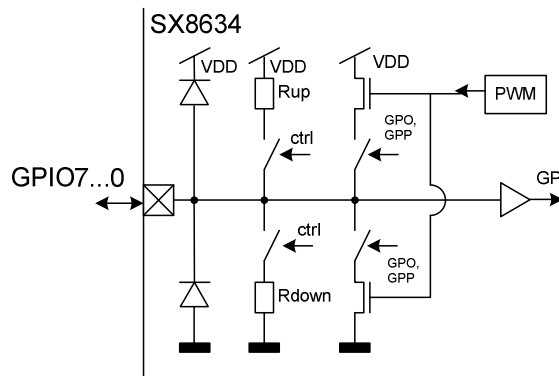

Figure 45 Simplified diagram of GPIO pins



SX8634
Low Power, Capacitive Button and Slider Touch Controller
(12 sensors) with Enhanced LED Drivers and Proximity Sensing

ADVANCED COMMUNICATIONS & SENSING

DATASHEET

5 DETAILED CONFIGURATION DESCRIPTIONS

5.1 Introduction

The SX8634 configuration parameters are taken from the QSM or the NVM and loaded into the SPM as explained in the chapter 'functional description'.

This chapter describes the details of the configuration parameters of the SX8634.

The SPM is split by functionality into 6 configuration sections:

- General section: operating modes,
- Capacitive Sensors section: related to lower level capacitive sensing,
- Button: related to the conversion from sensor data towards button information,
- Slider: related to the conversion from sensor data towards slider information,
- Mapping: related to mapping of button and slider information towards wake-up and GPIO pins,
- GPIO: related to the setup of the GPIO pins.

The total address space of the SPM and the NVM is 128 bytes, from address 0x00 to address 0x7F.

Two types of memory addresses, data are accessible to the user.

- 'application data': Application dependent data that need to be configured by the user.
- 'reserved': Data that need to be maintained by the user to the QSM default values (i.e. when NVM is burned).

The Table 12 and Table 13 resume the complete SPM address space and show the 'application data' and 'reserved' addresses, the functional split and the default values (loaded from the QSM).



SX8634
 Low Power, Capacitive Button and Slider Touch Controller
 (12 sensors) with Enhanced LED Drivers and Proximity Sensing

ADVANCED COMMUNICATIONS & SENSING DATASHEET

Address	Name	default QSM value
0x00	Reserved	0xxx
0x01	Reserved	0xxx
0x02	Reserved	0x11
0x03	Reserved	0xxx
0x04	General	I2CAddress 0x2B
0x05		ActiveScanPeriod 0x02
0x06		DozeScanPeriod 0x0D
0x07		PassiveTimer 0x00
0x08	Reserved	0x00
0x09	Capacitive Sensors	CapModeMisc 0x01
0x0A		CapMode11_8 0xAA
0x0B		CapMode7_4 0xA5
0x0C		CapMode3_0 0x55
0x0D		CapSensitivity0_1 0x00
0x0E		CapSensitivity2_3 0x00
0x0F		CapSensitivity4_5 0x00
0x10		CapSensitivity6_7 0x00
0x11		CapSensitivity8_9 0x00
0x12		CapSensitivity10_11 0x00
0x13		CapThresh0 0xA0
0x14		CapThresh1 0xA0
0x15		CapThresh2 0xA0
0x16		CapThresh3 0xA0
0x17		CapThresh4 0xA0
0x18		CapThresh5 0xA0
0x19		CapThresh6 0xA0
0x1A	CapThresh7 0xA0	
0x1B	CapThresh8 0xA0	
0x1C	CapThresh9 0xA0	
0x1D	CapThresh10 0xA0	
0x1E	CapThresh11 0xA0	
0x1F	CapPerComp 0x00	

Address	Name	default QSM value	
0x20	Reserved	0x00	
0x21	Button	BtnCfg 0x30	
0x22		BtnAvgThresh 0x50	
0x23		BtnCompNegThresh 0x50	
0x24		BtnCompNegCntMax 0x01	
0x25		BtnHysteresis 0x0A	
0x26		BtnStuckAtTimeout 0x00	
0x27	Slider	SldCfg 0x00	
0x28		SldStuckAtTimeout 0x00	
0x29		SldHysteresis 0x03	
0x2A		Reserved 0xFF	
0x2B		SldNormMsb 0x01	
0x2C		SldNormLsb 0x80	
0x2D		SldAvgThresh 0x50	
0x2E		SldCompNegThresh 0x50	
0x2F		SldCompNegCntMax 0x01	
0x30		SldMoveThresh 0x02	
0x31		Reserved 0x00	
0x32		Reserved 0x00	
0x33		Mapping	MapWakeupSize 0x00
0x34			MapWakeupValue0 0x00
0x35	MapWakeupValue1 0x00		
0x36	MapWakeupValue2 0x00		
0x37	MapAutoLight0 0xFE		
0x38	MapAutoLight1 0x54		
0x39	MapAutoLight2 0x32		
0x3A	MapAutoLight3 0x10		
0x3B	MapAutoLightGrp0Msb 0x00		
0x3C	MapAutoLightGrp0Lsb 0x00		
0x3D	MapAutoLightGrp1Msb 0x00		
0x3E	MapAutoLightGrp1Lsb 0x00		
0x3F	MapSegmentHysteresis 0x02		

Table 12 SPM address map: 0x00...0x3F

Note

- '0xxx': write protected data



SX8634

Low Power, Capacitive Button and Slider Touch Controller
 (12 sensors) with Enhanced LED Drivers and Proximity Sensing

ADVANCED COMMUNICATIONS & SENSING DATASHEET

Address	Name	default QSM value
0x40	GpioMode7_4	0x00
0x41	GpioMode3_0	0x00
0x42	GpioOutPwrUp	0x00
0x43	GpioAutoLight	0xFF
0x44	GpioPolarity	0x00
0x45	GpioIntensityOn0	0xFF
0x46	GpioIntensityOn1	0xFF
0x47	GpioIntensityOn2	0xFF
0x48	GpioIntensityOn3	0xFF
0x49	GpioIntensityOn4	0xFF
0x4A	GpioIntensityOn5	0xFF
0x4B	GpioIntensityOn6	0xFF
0x4C	GpioIntensityOn7	0xFF
0x4D	GpioIntensityOff0	0x00
0x4E	GpioIntensityOff1	0x00
0x4F	GpioIntensityOff2	0x00
0x50	GpioIntensityOff3	0x00
0x51	GpioIntensityOff4	0x00
0x52	GpioIntensityOff5	0x00
0x53	GpioIntensityOff6	0x00
0x54	GpioIntensityOff7	0x00
0x55	Reserved	0xFF
0x56	GpioFunction	0x00
0x57	GpioIncFactor	0x00
0x58	GpioDecFactor	0x00
0x59	GpioIncTime7_6	0x00
0x5A	GpioIncTime5_4	0x00
0x5B	GpioIncTime3_2	0x00
0x5C	GpioIncTime1_0	0x00
0x5D	GpioDecTime7_6	0x44
0x5E	GpioDecTime5_4	0x44
0x5F	GpioDecTime3_2	0x44

Address	Name	default QSM value
0x60	GpioDecTime1_0	0x44
0x61	GpioOffDelay7_6	0x00
0x62	GpioOffDelay5_4	0x00
0x63	GpioOffDelay3_2	0x00
0x64	GpioOffDelay1_0	0x00
0x65	GpioPullUpDown7_4	0x00
0x66	GpioPullUpDown3_0	0x00
0x67	GpioInterrupt7_4	0x00
0x68	GpioInterrupt3_0	0x00
0x69	GpioDebounce	0x00
0x6A	Reserved	0x00
0x6B	Reserved	0x00
0x6C	Reserved	0x00
0x6D	Reserved	0x00
0x6E	Reserved	0x00
0x6F	Reserved	0x50
0x70	CapProxEnable	0x46
0x71	Reserved	0x10
0x72	Reserved	0x45
0x73	Reserved	0x02
0x74	Reserved	0xFF
0x75	Reserved	0xFF
0x76	Reserved	0xFF
0x77	Reserved	0xD5
0x78	Reserved	0x55
0x79	Reserved	0x55
0x7A	Reserved	0x7F
0x7B	Reserved	0x23
0x7C	Reserved	0x22
0x7D	Reserved	0x41
0x7E	Reserved	0xFF
0x7F	SpmCrc*	0x6F

Table 13 SPM address map: 0x40...0x7F

Note*

- SpmCrc: CRC depending on SPM content, updated in Active or Doze mode.



SX8634
 Low Power, Capacitive Button and Slider Touch Controller
 (12 sensors) with Enhanced LED Drivers and Proximity Sensing

ADVANCED COMMUNICATIONS & SENSING DATASHEET

5.2 General Parameters

General Parameters			
Address	Name	Bits	Description
0x04	I2CAddress	7	Reserved
		6:0	Defines the I2C address (default 0x2B). The I2C address will be active after a reset.
0x05	ActiveScanPeriod	7:0	Active Mode Scan Period (Figure 7) 0x00: Reserved 0x01: 15ms 0x02: 30ms (default) ... 0xFF: 255 x 15ms
0x06	DozeScanPeriod	7:0	Doze Mode Scan Period (Figure 7) 0x00: Reserved 0x01: 15ms ... 0x0D: 195ms (default) ... 0xFF: 255 x 15ms
0x07	PassiveTimer	7:0	Passive Timer on Button and Slider Information (Figure 8) 0x00: OFF (default) 0x01: 1 second ... 0xFF: 255 seconds

Table 14 General Parameters



SX8634
 Low Power, Capacitive Button and Slider Touch Controller
 (12 sensors) with Enhanced LED Drivers and Proximity Sensing

ADVANCED COMMUNICATIONS & SENSING DATASHEET

5.3 Capacitive Sensors Parameters

Capacitive Sensors Parameters																
Address	Name	Bits	Description													
0x09	CapModeMisc	7:3	Reserved													
		2:0	IndividualSensitivity	Defines common sensitivity for all sensors or individual sensor sensitivity. 001: Common settings (CapSensitivity0_1[7:4]) 100: Individual CAP sensitivity settings (CapSensitivityx_x) Else : Reserved												
0x0A	CapMode11_8	7:6	CAP11 Mode	Defines the mode of the CAP pin. 00: Disabled 01: Button 10: Slider 11: Reserved	Default	Slider										
		5:4	CAP10 Mode			Slider										
		3:2	CAP9 Mode			Slider										
		1:0	CAP8 Mode			Slider										
0x0B	CapMode7_4	7:6	CAP7 Mode			Defines the mode of the CAP pin. 00: Disabled 01: Button 10: Slider 11: Reserved	Default	Slider								
		5:4	CAP6 Mode					Slider								
		3:2	CAP5 Mode					Button								
		1:0	CAP4 Mode					Button								
0x0C	CapMode3_0	7:6	CAP3 Mode					Defines the mode of the CAP pin. 00: Disabled 01: Button 10: Slider 11: Reserved	Default	Button						
		5:4	CAP2 Mode							Button						
		3:2	CAP1 Mode							Button						
		1:0	CAP0 Mode							Button						
0x0D	CapSensitivity0_1	7:4	CAP0 Sensitivity - Common Sensitivity		Defines the sensitivity. 0x0: Minimum (default) 0x7: Maximum 0x8...0xF: Reserved											
		3:0	CAP1 Sensitivity													
0x0E	CapSensitivity2_3	7:4	CAP2 Sensitivity								Defines the sensitivity. 0x0: Minimum (default) 0x7: Maximum 0x8...0xF: Reserved					
		3:0	CAP3 Sensitivity													
0x0F	CapSensitivity4_5	7:4	CAP4 Sensitivity			Defines the sensitivity. 0x0: Minimum (default) 0x7: Maximum 0x8...0xF: Reserved										
		3:0	CAP5 Sensitivity													
0x10	CapSensitivity6_7	7:4	CAP6 Sensitivity										Defines the sensitivity. 0x0: Minimum (default) 0x7: Maximum 0x8...0xF: Reserved			
		3:0	CAP7 Sensitivity													
0x11	CapSensitivity8_9	7:4	CAP8 Sensitivity					Defines the sensitivity. 0x0: Minimum (default) 0x7: Maximum 0x8...0xF: Reserved								
		3:0	CAP9 Sensitivity													
0x12	CapSensitivity10_11	7:4	CAP10 Sensitivity												Defines the sensitivity. 0x0: Minimum (default) 0x7: Maximum 0x8...0xF: Reserved	
		3:0	CAP11 Sensitivity													
0x13	CapThresh0	7:0	CAP0 Touch Threshold		Defines the Touch Threshold ticks. 0x00: 0, 0x01: 4, ... 0xA0: 640 (default), ... 0xFF: 1020											
0x14	CapThresh1	7:0	CAP1 Touch Threshold													
0x15	CapThresh2	7:0	CAP2 Touch Threshold													
0x16	CapThresh3	7:0	CAP3 Touch Threshold													
0x17	CapThresh4	7:0	CAP4 Touch Threshold													
0x18	CapThresh5	7:0	CAP5 Touch Threshold													
0x19	CapThresh6	7:0	CAP6 Touch Threshold													



Low Power, Capacitive Button and Slider Touch Controller
 (12 sensors) with Enhanced LED Drivers and Proximity Sensing

ADVANCED COMMUNICATIONS & SENSING DATASHEET

Capacitive Sensors Parameters			
Address	Name	Bits	Description
0x1A	CapThresh7	7:0	CAP7 Touch Threshold
0x1B	CapThresh8	7:0	CAP8 Touch Threshold
0x1C	CapThresh9	7:0	CAP9 Touch Threshold
0x1D	CapThresh10	7:0	CAP10 Touch Threshold
0x1E	CapThresh11	7:0	CAP11 Touch Threshold
0x1F	CapPerComp	7:4	Reserved
		3:0	Periodic Offset Compensation Defines the periodic offset compensation. 0x0: OFF (default) 0x1: 1 second 0x2: 2 seconds ... 0x7: 7 seconds 0x8: 16 seconds 0x9: 18 seconds ... 0xE: 28 seconds 0xF: 60 seconds
0x70	CapProxEnable	7:0	Enables proximity sensing: 0x46: OFF 0x74: ON

Table 15 Capacitive Sensors Parameters

CapModeMisc

By default the ASI is using a common sensitivity for all capacitive sensors as in the usual case overlay material and sensors sizes are about equal. The register bits CapSensitivity0_1[7:4] determine the sensitivity for all sensors in common sensitivity mode.

It might be required to have a different, individual, sensitivity for each CAP pin (for example proximity sensor set to max sensitivity while touch sensors are set to a lower one). This can be obtained by setting CapModeMisc[2:0] to "100" The individual sensitivity mode results in longer sensing periods than required in common sensitivity mode.

CapMode11_8, CapMode7_4, CapMode3_0:

The CAP pins can be set as a button, part of a slider or disabled depending on the application.

	minimum	default	maximum
buttons	zero	six	eight
slider	one (of four sensors)	one (of six sensors)	one (of twelve sensors)

Table 16 Possible CAP pin modes



Low Power, Capacitive Button and Slider Touch Controller
 (12 sensors) with Enhanced LED Drivers and Proximity Sensing

ADVANCED COMMUNICATIONS & SENSING DATASHEET

Buttons and disabled CAP pins can be attributed freely (examples in Figure 46). All buttons can be used for touch or proximity sensing, in the latter case register CapProxEnable needs to be set accordingly.

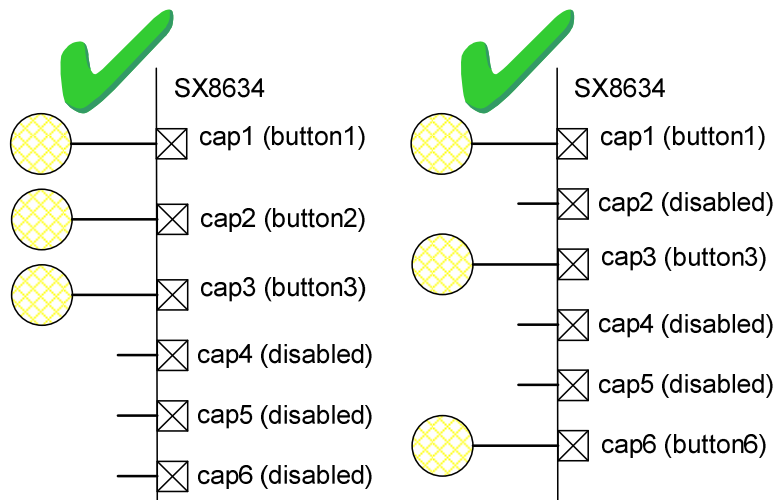

Figure 46 Button examples

Disabled CAP pins inside the slider sensor attribution sequence are allowed, but CAP buttons inside a slider are not allowed (see example Figure 47 with CAP3 in a correct and a not allowed configuration).

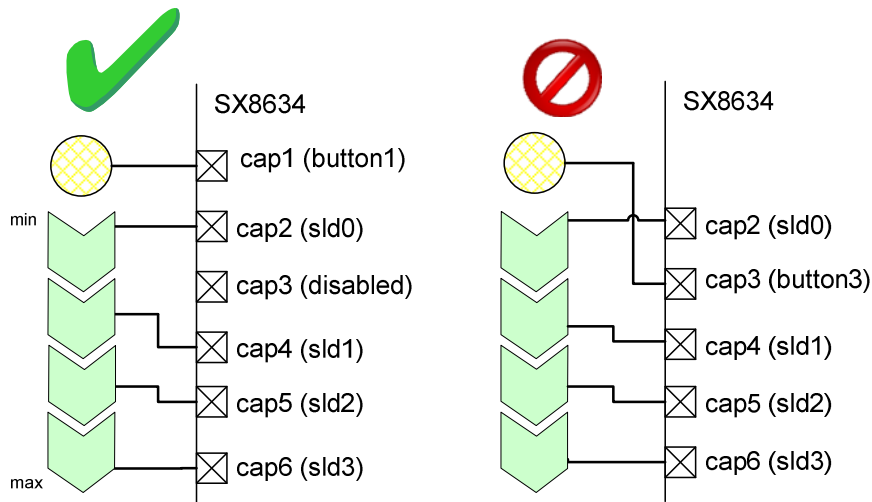

Figure 47 Button and Slider good/bad configuration examples (I)

The physical order of the slider sensors on the PCB should correspond to the incremental CAP pin numbers. Crossing slider PCB sensors and CAP number is not allowed. Figure 48 shows a valid configuration and a wrong configuration where CAP5 and CAP6 are not routed correctly on the PCB.

SX8634



Low Power, Capacitive Button and Slider Touch Controller
 (12 sensors) with Enhanced LED Drivers and Proximity Sensing

ADVANCED COMMUNICATIONS & SENSING DATASHEET

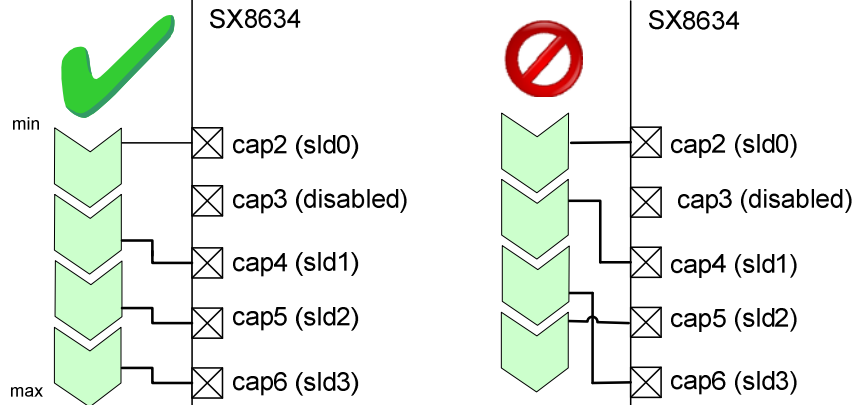

Figure 48 Button and Slider good/bad configuration examples (II)

The minimum position of the slider is associated to the CAP pin, attributed to the slider, with the lowest index (in Figure 48 this is CAP2).
 The maximum position of the slider is associated to the CAP pin, attributed to the slider, with the highest index (in Figure 48 this is CAP6).

CapSensitivity0_1, CapSensitivity2_3, CapSensitivity4_5,
 CapSensitivity6_7, CapSensitivity8_9, CapSensitivity10_11, CapProxEnable:

The sensitivity of the sensors can be set between 8 values. The higher the sensitivity is set the larger the value of the ticks will be.
 The minimum sensitivity can be used for thin overlay materials and large sensors, while the maximum sensitivity is required for thicker overlay and smaller sensors or proximity sensing.
 The required sensitivity needs to be determined during a product development phase. Too low sensitivity settings result in missing touches. Too high sensitivity settings will result in fault detection of fingers hovering above the touch sensors.
 The sensitivity is identical for all sensors in common sensitivity mode using the bits CapSensitivity0_1[7:4] and can be set individually using register CapModeMisc[2:0].

The maximum number of ticks that can be obtained depends on the selected sensitivity and if proximity sensing is enabled. This is illustrated in Table 17.

Sensitivity	Approximate Maximum Tick Level (CapProxEnable = OFF)	Approximate Maximum Tick Level (CapProxEnable = ON)
0	1000	4000
1	2000	8000
2	3000	12000
3	4000	16000
4	5000	20000
5	6000	24000
6	7000	28000
7	8000	32000

Table 17 ASI Maximum Tick Levels

**SEMTECH**Low Power, Capacitive Button and Slider Touch Controller
(12 sensors) with Enhanced LED Drivers and Proximity Sensing**SX8634****ADVANCED COMMUNICATIONS & SENSING****DATASHEET**

CapThresh0, CapThresh1, CapThresh2, CapThresh3, CapThresh4, CapThresh5, CapThresh6, CapThresh7, CapThresh8, CapThresh9, CapThresh10, CapThresh11:

For each CAP pin a threshold level can be set individually.

The threshold levels are used by the SX8634 for making touch and release decisions on e.g. touch or no-touch.

The details are explained in the sections for buttons and slider.

CapPerComp:

The SX8634 offers a periodic offset compensation for applications which are subject to substantial environmental changes. The periodic offset compensation is done at a defined interval and only if slider and buttons are released.



SX8634
 Low Power, Capacitive Button and Slider Touch Controller
 (12 sensors) with Enhanced LED Drivers and Proximity Sensing

ADVANCED COMMUNICATIONS & SENSING DATASHEET

5.4 Button Parameters

Button Parameters			
Address	Name	Bits	Description
0x21	BtnCfg	7:6	Defines the buttons events reporting method. 00: Multiple reporting of all touches and releases (default) 01: Single reporting of the first button touch. Next button touches and releases are ignored until release of the first button. 10: Reserved 11: Reserved
		5:4	Defines the buttons interrupt (for all buttons) 00 : Interrupts masked 01 : Triggered on Touch 10 : Triggered on Release 11 : Triggered on Touch and Release (default)
		3:2	Defines the number of samples at the scan period for determining a release 00: OFF, use incoming sample (default) 01: 2 samples debounce 10: 3 samples debounce 11: 4 samples debounce
		1:0	Defines the number of samples at the scan period for determining a touch 00: OFF, use incoming sample (default) 01: 2 samples debounce 10: 3 samples debounce 11: 4 samples debounce
0x22	BtnAvgThresh	7:0	Defines the positive threshold for disabling the processing filter averaging. If ticks are above the threshold, then the averaging is suspended 0x00: 0 0x01: 4 ... 0x50: 320 (default) ... 0xFF: 1020
0x23	BtnCompNegThresh	7:0	Defines the negative offset compensation threshold. 0x00: 0 0x01: 4 ... 0x50: 320 (default) ... 0xFF: 1020
0x24	BtnCompNegCntMax	7:0	Defines the number of ticks (below the negative offset compensation threshold) which will initiate an offset compensation. 0x00: Reserved 0x01: 1 sample (default) ... 0xFF-> samples
0x25	BtnHysteresis	7:0	Defines the button hysteresis corresponding to a percentage of the CAP thresholds (defined in Table 18). 0x00: 0% ... 0x0A: 10% (default) ... 0x64: 100% All buttons use the same hysteresis
0x26	BtnStuckAtTimeout	7:0	Defines the stuck at timeout. 0x00: OFF (default)

SX8634



Low Power, Capacitive Button and Slider Touch Controller
 (12 sensors) with Enhanced LED Drivers and Proximity Sensing

ADVANCED COMMUNICATIONS & SENSING DATASHEET

Button Parameters			
Address	Name	Bits	Description
			0x01: 1 second
			...
			0xFF: 255 seconds

Table 18 Button Configuration Parameters

Please note that proximity sensors are configured as buttons and operate exactly the same way as touch buttons. All the parameters and procedures described below apply similarly.

A reliable button operation requires a coherent setting of the registers. Figure 49 shows an example of a touch and a release. The ticks will vary slightly around the zero idle state. When the touch occurs the ticks will rise sharply. At the release of the button the ticks will go down rapidly and converge to the idle zero value.

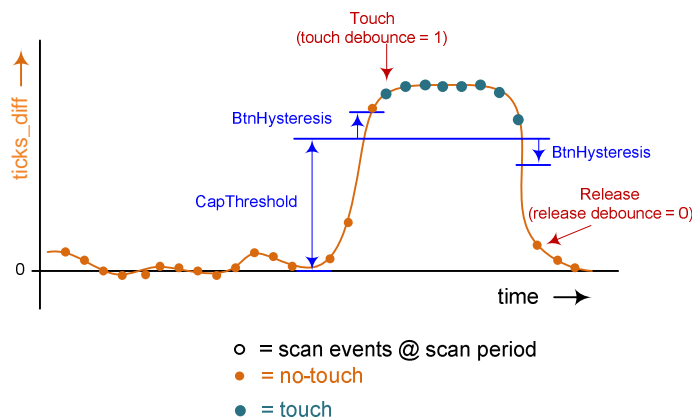

Figure 49 Touch and Release Example

As soon as the ticks become larger than the CAP thresholds (see registers of the previous section) plus the hysteresis (defined in register BtnHysteresis) the debounce counter starts. In the example of Figure 49 the touch is validated after 2 samples (BtnCfg [1:0] = 01). The release is detected immediately (BtnCfg [3:2] = 00) at the first sample which is below the threshold minus the hysteresis.

BtnCfg

The SX8634 can report all touches of multiple fingers or the SX8634 can be set to report only the first detected touch. In the later case all succeeding touches are ignored. The very first touch should be released before a next touch will be detected.

The user can select to have the interrupt signal on touching a button, releasing a button or both

In noisy environments it may be required to debounce the touch and release detection decision. In case the debounce is enabled the SX8634 will count up to the number of debounce samples BtnCfg [1:0], BtnCfg [3:2] before taking a touch or release decision. The sample period is identical to the scan period.

BtnAvgThresh

Small environmental and system noise cause the ticks to vary slowly around the zero idle mode value.

SX8634



Low Power, Capacitive Button and Slider Touch Controller
 (12 sensors) with Enhanced LED Drivers and Proximity Sensing

ADVANCED COMMUNICATIONS & SENSING DATASHEET

In case the ticks get slightly positive this is considered as normal operation. Very large positive tick values indicate a valid touch. The averaging filter is disabled as soon as the average reaches the value defined by BtnAvgThresh. This mechanism avoids that a valid touch will be averaged and finally the tick difference becomes zero.

In case three or more sensors reach the BtnAvgThresh value simultaneously then the SX8634 will start an offset compensation procedure.

Small environmental and system noise cause the ticks to vary slowly around the zero idle mode value. In case the ticks get slightly negative this is considered as normal operation. However large negative values will trigger an offset compensation phase and a new set of DCVs will be obtained. The decision to trigger a compensation phase based on negative ticks is determined by the value in the register BtnCompNegThresh and by the number of ticks below the negative thresholds defined in register BtnCompNegCntMax. An example is shown in Figure 50.

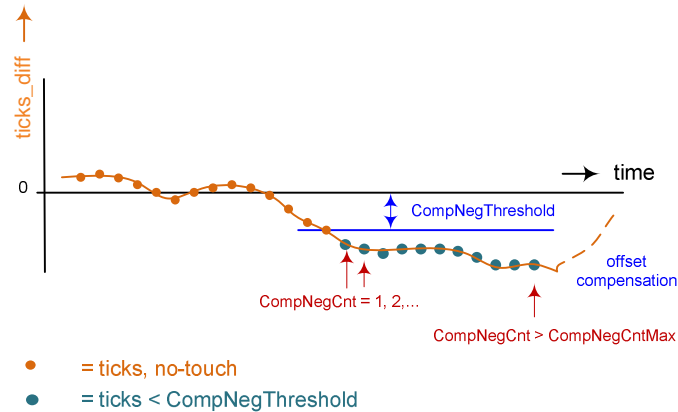

Figure 50 Negative Ticks Offset Compensation Trigger

BtnCompNegThresh

Small negative ticks are considered as normal operation and will occur very often. Larger negative ticks however need to be avoided and a convenient method is to trigger an offset compensation phase. The new set of DCV will assure the idle ticks will be close to zero again. A trade-off has to be found for the value of this register. A negative threshold too close to zero will trigger a compensation phase very often. A very negative threshold will never trigger.

BtnCompNegCntMax

As soon as the ticks get smaller than the Negative Threshold the Negative Counter starts to count. If the counter goes beyond the Negative Counter Max then the offset compensation phase is triggered. The recommended value for this register is '1' which means that the offset compensation starts on the first tick below the negative threshold.

BtnHysteresis

The hysteresis percentage is identical for all buttons.
 A touch is detected if the ticks are getting larger as the value defined by:
 $CapThreshold + CapThreshold * hysteresis.$

A release is detected if the ticks are getting smaller as the value defined by:
 $CapThreshold - CapThreshold * hysteresis.$

BtnStuckAtTimeout



SEMTECH

Low Power, Capacitive Button and Slider Touch Controller
(12 sensors) with Enhanced LED Drivers and Proximity Sensing

SX8634

ADVANCED COMMUNICATIONS & SENSING

DATASHEET

The stuckat timer can avoid sticky buttons.

If the stuckat timer is set to one second then the touch of a finger will last only for one second and then a compensation will be performed and button hence considered released, even if the finger remains on the button for a longer time. After the actual finger release the button can be touched again and will be reported as usual.

In case the stuckat timer is not required it can be set to zero.



SX8634
 Low Power, Capacitive Button and Slider Touch Controller
 (12 sensors) with Enhanced LED Drivers and Proximity Sensing

ADVANCED COMMUNICATIONS & SENSING DATASHEET

5.5 Slider Parameters

Slider Parameters				
Address	Name	Bits	Description	
0x27	SldCfg	7:4	Reserved	
		3:2	Defines the number of samples at the scan period for determining a release 00: OFF, use incoming sample (default) 01: 2 samples debounce 10: 3 samples debounce 11: 4 samples debounce	
		1:0	Defines the number of samples at the scan period for determining a touch 00: OFF, use incoming sample (default) 01: 2 samples debounce 10: 3 samples debounce 11: 4 samples debounce	
0x28	SldStuckAtTimeout	7:0	Defines the stuck at timeout. 0x00: OFF (default) 0x01: 1 second ... 0xFF: 255 seconds	
0x29	SldHysteresis	7:0	Defines the Slider Touch/Release Hysteresis. 0x00: 0 0x01: 4 ... 0x03: 12 (default) ... 0xFF: 1020	
0x2B	SldNormMsb	7:0	Slider Norm Msb	Defines the 16 bits slider norm (default 0x0180)
0x2C	SldNormLsb	7:0	Slider Norm Lsb	
0x2D	SldAvgThresh	7:0	Defines the positive threshold for disabling the processing filter averaging. If ticks are above the threshold, then the averaging is suspended 0x00: 0 0x01: 4 ... 0x50: 320 (default) ... 0xFF: 1020	
0x2E	SldCompNegThresh	7:0	Defines the negative offset compensation threshold. 0x00: 0 0x01: 4 ... 0x50: 320 (default) ... 0xFF: 1020	
0x2F	SldCompNegCntMax	7:0	Defines the number of ticks (below the negative offset compensation threshold) which will initiate an offset compensation. 0x00: Reserved 0x01: 1 sample (default) ... 0xFF: 255 samples	
0x30	SldMoveThresh	7:0	Defines the threshold for detecting a move high or move low. The threshold is a percentage of the maximum slider position. 0x00: 0% ... 0x02: 2% (default)	

SX8634



SEMTECH

Low Power, Capacitive Button and Slider Touch Controller
 (12 sensors) with Enhanced LED Drivers and Proximity Sensing

ADVANCED COMMUNICATIONS & SENSING DATASHEET

Slider Parameters			
Address	Name	Bits	Description
			... 0x64: 100% A succeeding position difference, at the scan period, above the threshold is considered as a move high or move low.

Table 19 Slider Parameters



Low Power, Capacitive Button and Slider Touch Controller
 (12 sensors) with Enhanced LED Drivers and Proximity Sensing

ADVANCED COMMUNICATIONS & SENSING DATASHEET

The pressure represents the finger touch on the sensors of the slider and it used to determine if a slider is touched or released.

$$SldPressure = \sum_{i=0}^{N-1} (ticks_diff(i) - CapThresh(i))$$

- N is the number of sensors,
- A sensor with ticks smaller than the CapThreshold is not taken into account for calculating the pressure

In case the pressure equals zero the slider status is released.
 In case the pressure is larger as the Slider Hysteresis the slider status is touched.

The position of a finger on a slider is calculated by the centre of gravity algorithm.

$$SldPos = \frac{SldNorm}{32} * \frac{\sum_{i=0}^{N-1} i * (ticks_diff(i) - CapThresh(i))}{\sum_{i=0}^{N-1} (ticks_diff(i) - CapThresh(i))}$$

- N is the number of sensors,
- A sensor with ticks smaller than the CapThreshold is not taken into account for calculating the position,
- SldNorm[15:0] is a 16 bit number determined by SldNormMsb[15:8] and SldNormLsb[7:0].
- SldPos is the slider position (16 bits) which can be read by the host over the I2C registers SldPosMsb and SldPosLsb

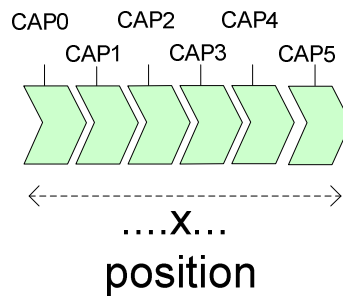

Figure 51 Slider Position

Figure 51 shows an example of a slider composed of 6 sensors (CAP0, CAP1... CAP5).
 The default slider norm value 12 (SldNormMsb = 0x01, SldNormLsb = 0x80), is taken for the example.
 A touch on CAP0 gives the slider position: 0.
 A touch on CAP1 gives the slider position: 12.
 A touch on CAP5 gives the slider position: 60.

If a touch occurs on CAP0 and CAP1 the centre of gravity algorithm will interpolate.
 Assuming the touch is identically distributed on CAP0 and CAP1 then the position will be: 6
 Assuming the touch is identically distributed on CAP1 and CAP2 then the position will be: 18
 Assuming the touch is identically distributed on CAP4 and CAP5 then the position will be: 54

The maximum slider position (for this example) that can be obtained is 60.

The minimum position of a slider equals 0.



SX8634
 Low Power, Capacitive Button and Slider Touch Controller
 (12 sensors) with Enhanced LED Drivers and Proximity Sensing

ADVANCED COMMUNICATIONS & SENSING DATASHEET

The maximum position (SldPosMax) is defined by:

$$SldPosMax = \frac{SldNorm}{32} \times (N - 1)$$

with:

N is the number of sensors in the slider

Slow varying slider ticks due to environmental changes are handled as buttons in the previous section.

If the ticks pass below the slider negative threshold for more than the compensation negative max counter then an offset compensation phase will be triggered.

If the ticks pass above the slider average positive threshold then the averaging filters will be held.

A finger that moves very slowly over the slider is not considered as a movement. The status move low and move high will not be set.

A finger that moves faster on the slider will change the movement status.

A movement is detected if the difference of the position for two succeeding samples at the scanning rate goes beyond the movement threshold (SldMoveThresh). A large movement threshold requires very rapid finger movements, while a small movement threshold detects more easily movements but gets sensitive to noise variations as well.



SX8634

Low Power, Capacitive Button and Slider Touch Controller
 (12 sensors) with Enhanced LED Drivers and Proximity Sensing

ADVANCED COMMUNICATIONS & SENSING DATASHEET

5.6 Mapping Parameters

Mapping Parameters			
Address	Name	Bits	Description
0x33	MapWakeupSize	7:3	Reserved
		2:0	Doze -> Active wake up sequence size. 0: Any sensor event (default) 1: key0 2: key0, key1 ... 6: key0, key1,...key5 7: No sensor event, only GPI or I2C cmd can exit Doze mode Each key must be followed by a release to be validated. Any other sensor event before the release is ignored. Any wrong key implies the whole sequence to be entered again.
0x34	MapWakeupValue0	7:4	key5
		3:0	key4
0x35	MapWakeupValue1	7:4	key3
		3:0	key2
0x36	MapWakeupValue2	7:4	key1
		3:0	key0
0x37	MapAutoLight0	7:4	GPIO[7]
		3:0	GPIO[6]
0x38	MapAutoLight1	7:4	GPIO[5]
		3:0	GPIO[4]
0x39	MapAutoLight2	7:4	GPIO[3]
		3:0	GPIO[2]
0x3A	MapAutoLight3	7:4	GPIO[1]
		3:0	GPIO[0]
0x3B	MapAutoLightGrp0Msb	7	Reserved
		6	Segment
		5	Move High
		4	Move Low
		3	Btn11
		2	Btn10
		1	Btn9
		0	Btn8
0x3C	MapAutoLightGrp0Lsb	7	Btn7
		6	Btn6
		5	Btn5
		4	Btn4
		3	Btn3



SX8634

Low Power, Capacitive Button and Slider Touch Controller
 (12 sensors) with Enhanced LED Drivers and Proximity Sensing

ADVANCED COMMUNICATIONS & SENSING DATASHEET

Mapping Parameters			
Address	Name	Bits	Description
		2	Btn2
		1	Btn1
		0	Btn0
0x3D	MapAutoLightGrp1Msb	7	Reserved
		6	Slider Touch
		5	Move High
		4	Move Low
		3	Btn11
		2	Btn10
		1	Btn9
		0	Btn8
0x3E	MapAutoLightGrp1Lsb	7	Btn7
		6	Btn6
		5	Btn5
		4	Btn4
		3	Btn3
		2	Btn2
		1	Btn1
		0	Btn0
0x3F	MapSegmentHysteresis	7:0	<p>Defines the position hysteresis for detecting a segment change. The hysteresis is defined as a percentage of the maximum slider position.</p> <p>0x00: 0% ... 0x02: 2% (default) ... 0x64: 100%</p> <p>This hysteresis applies to all segments of the slider.</p>

Table 20 Mapping Parameters

MapWakeupSize

The number of keys defining the wakeup sequence can be set from 1 to 6. If the size is set to 0 then wakeup is done on any sensor event. If the size is set to 6 then wakeup is done only by GPI or an I2C command (may be required if proximity sensing is enable, see §3.17 for more details).

MapWakeupValue0, MapWakeupValue1, MapWakeupValue2

For the wakeup sequence Btn2 -> Btn5 -> Btn6 -> Btn0 the required register settings are:

- MapWakeupSize set to 0x04,
- key0 = 0x2
- key1 = 0x5



Low Power, Capacitive Button and Slider Touch Controller
 (12 sensors) with Enhanced LED Drivers and Proximity Sensing

ADVANCED COMMUNICATIONS & SENSING DATASHEET

- => MapWakeupValue2 set to 0x52
- key2 = 0x6
- key3 = 0x0
- => MapWakeupValue2 set to 0x06

MapAutoLight0, MapAutoLight1, MapAutoLight2, MapAutoLight3
 MapAutoLightGrp0Msb, MapAutoLightGrp0Lsb, MapAutoLightGrp1Msb, MapAutoLightGrp1Lsb

These registers define the mapping between the GPO pins (with Autolight ON) and the sensor information which will control its ON/OFF state. The mapping can be done to a specific sensor event but also on groups (in this case any sensor event in the group will control the GPO).

Table 21 defines for each selectable sensor event, which action will trigger corresponding GPO to switch ON or OFF.

MapAutoLight	GPO ON	GPO OFF
BtnX	Touch	Release
Slider Touch	Touch	Release
Slider Move High	Move High	Move Low or Release
Slider Move Low	Move Low	Move High or Release
Slider Segment	Segment Touched	Segment Released

Table 21 Autolight Mapping, Sensor Information

Examples:

- If GPO[0] should change state accordingly to Btn4 then MapAutoLight3[3:0] should be set to 0x04.
- If GPO[0] should change state accordingly to Btn0 or Btn1 then Group0 can be used as following:
 - MapAutoLight3[3:0] should be set to 0x0C (ie Group0).
 - MapAutoLightGrp0 should be set to 0x0003 (ie Btn0 or Btn1)

When the Slider Segment event is mapped, the number of GPOs mapped to it determines the number of slider segments. The GPO with the lowest pin index is mapped on the segment with the smallest positions. E.g. if two GPOs (e.g. GPO[0] and GPO[1]) are mapped to the Slider Segment event then the slider is split in two segments. GPO[0] will turn ON for a touch on the slider segment [0, SldPosMax/2] and GPO[1] for a touch on the slider segment [SldPosMax/2, SldPosMax].



SX8634
 Low Power, Capacitive Button and Slider Touch Controller
 (12 sensors) with Enhanced LED Drivers and Proximity Sensing

ADVANCED COMMUNICATIONS & SENSING DATASHEET

5.7 GPIO Parameters

GPIO Parameters						
Address	Name	Bits	Description			
0x40	GpioMode7_4	7:6	GPIO[7] Mode	Defines the GPIO mode. 00: GPO (default) 01: GPP 10: GPI 11: Reserved		
		5:4	GPIO[6] Mode			
		3:2	GPIO[5] Mode			
		1:0	GPIO[4] Mode			
0x41	GpioMode3_0	7:6	GPIO[3] Mode			
		5:4	GPIO[2] Mode			
		3:2	GPIO[1] Mode			
		1:0	GPIO[0] Mode			
0x42	GpioOutPwrUp	7:0	GPIO[7] Output Value at Power Up	Defines the values of GPO and GPP pins after power up ie default values of I2C parameters GpoCtrl and GppIntensity respectively. 0: OFF(GPO) / IntensityOff (GPP) (default) 1: ON (GPO) / IntensityOn (GPP)		
			GPIO[6] Output Value at Power Up			
			GPIO[5] Output Value at Power Up			
			GPIO[4] Output Value at Power Up			
			GPIO[3] Output Value at Power Up		Bits corresponding to GPO pins with Autolight ON should be left to 0.	
			GPIO[2] Output Value at Power Up			
			GPIO[1] Output Value at Power Up			Before being actually initialized GPIOs are set as inputs with pull up.
			GPIO[0] Output Value at Power Up			
0x43	GpioAutoLight	7:0	GPIO[7] AutoLight	Enables Autolight in GPO mode 0 : OFF 1 : ON (default)		
			GPIO[6] AutoLight			
			GPIO[5] AutoLight			
			GPIO[4] AutoLight			
			GPIO[3] AutoLight			
			GPIO[2] AutoLight			
			GPIO[1] AutoLight			
			GPIO[0] AutoLight			
0x44	GpioPolarity	7:0	GPIO[7] Output Polarity	Defines the polarity of the GPO and GPP pins. 0: Inverted (default) 1: Normal		
			GPIO[6] Output Polarity			
			GPIO[5] Output Polarity			
			GPIO[4] Output Polarity			
			GPIO[3] Output Polarity			
			GPIO[2] Output Polarity			
			GPIO[1] Output Polarity			
			GPIO[0] Output Polarity			
0x45	GpioIntensityOn0	7:0	ON Intensity Index	Defines the ON intensity index 0x00: 0 0x01: 1		
0x46	GpioIntensityOn1					
0x47	GpioIntensityOn2					



SX8634

Low Power, Capacitive Button and Slider Touch Controller
 (12 sensors) with Enhanced LED Drivers and Proximity Sensing

ADVANCED COMMUNICATIONS & SENSING DATASHEET

GPIO Parameters				
Address	Name	Bits	Description	
0x48	GpioIntensityOn3			... 0xFF: 255 (default)
0x49	GpioIntensityOn4			
0x4A	GpioIntensityOn5			
0x4B	GpioIntensityOn6			
0x4C	GpioIntensityOn7			
0x4D	GpioIntensityOff0	7:0	OFF Intensity Index	Defines the OFF intensity index 0x00: 0 (default) 0x01: 1 ... 0xFF: 255
0x4E	GpioIntensityOff1			
0x4F	GpioIntensityOff2			
0x50	GpioIntensityOff3			
0x51	GpioIntensityOff4			
0x52	GpioIntensityOff5			
0x53	GpioIntensityOff6			
0x54	GpioIntensityOff7			
0x56	GpioFunction			
		GPIO[6] Function		
		GPIO[5] Function		
		GPIO[4] Function		
		GPIO[3] Function		
		GPIO[2] Function		
		GPIO[1] Function		
		GPIO[0] Function		
0x57	GpioIncFactor	7:0	GPIO[7] Fading Increment Factor	Defines the fading increment factor. 0: 1, intensity index incremented every increment time (default) 1: 16, intensity index incremented every 16 increment times
			GPIO[6] Fading Increment Factor	
			GPIO[5] Fading Increment Factor	
			GPIO[4] Fading Increment Factor	
			GPIO[3] Fading Increment Factor	
			GPIO[2] Fading Increment Factor	
			GPIO[1] Fading Increment Factor	
			GPIO[0] Fading Increment Factor	
0x58	GpioDecFactor	7:0	GPIO[7] Fading Decrement Factor	Defines the fading decrement factor. 0: 1, intensity index decremented every decrement time (default) 1: 16, intensity index decremented every 16 decrement times
			GPIO[6] Fading Decrement Factor	
			GPIO[5] Fading Decrement Factor	
			GPIO[4] Fading Decrement Factor	
			GPIO[3] Fading Decrement Factor	
			GPIO[2] Fading Decrement Factor	
			GPIO[1] Fading Decrement Factor	
			GPIO[0] Fading Decrement Factor	
0x59	GpioIncTime7_6	7:4	GPIO[7] Fading Increment Time	Defines the fading increment time.



SX8634

Low Power, Capacitive Button and Slider Touch Controller
 (12 sensors) with Enhanced LED Drivers and Proximity Sensing

ADVANCED COMMUNICATIONS & SENSING DATASHEET

GPIO Parameters				
Address	Name	Bits	Description	
		3:0	GPIO[6] Fading Increment Time	0x0: OFF (default)
0x5A	GpioIncTime5_4	7:4	GPIO[5] Fading Increment Time	0x1: 0.5ms
		3:0	GPIO[4] Fading Increment Time	0x2: 1ms
0x5B	GpioIncTime3_2	7:4	GPIO[3] Fading Increment Time	...
		3:0	GPIO[2] Fading Increment Time	0xF: 7.5ms
0x5C	GpioIncTime1_0	7:4	GPIO[1] Fading Increment Time	The total fading in time will be: GpioIncTime*GpioIncFactor*
		3:0	GPIO[0] Fading Increment Time	(GpioIntensityOn – GpioIntensityOff)
0x5D	GpioDecTime7_6	7:4	GPIO[7] Fading Decrement Time	Defines the fading decrement time.
		3:0	GPIO[6] Fading Decrement Time	0x0: OFF
0x5E	GpioDecTime5_4	7:4	GPIO[5] Fading Decrement Time	0x1: 0.5ms
		3:0	GPIO[4] Fading Decrement Time	0x2: 1ms
0x5F	GpioDecTime3_2	7:4	GPIO[3] Fading Decrement Time	...
		3:0	GPIO[2] Fading Decrement Time	0x4: 2.0ms (default)
0x60	GpioDecTime1_0	7:4	GPIO[1] Fading Decrement Time	...
		3:0	GPIO[0] Fading Decrement Time	0xF: 7.5ms
0x61	GpioOffDelay7_6	7:4	GPIO[7] OFF Delay	The total fading out time will be: GpioDecTime*GpioDecFactor*
		3:0	GPIO[6] OFF Delay	(GpioIntensityOn – GpioIntensityOff)
0x62	GpioOffDelay5_4	7:4	GPIO[5] OFF Delay	Defines the delay after GPO OFF trigger before fading out starts.
		3:0	GPIO[4] OFF Delay	0x0: OFF (default)
0x63	GpioOffDelay3_2	7:4	GPIO[3] OFF Delay	0x1: 200ms
		3:0	GPIO[2] OFF Delay	0x2: 400ms
0x64	GpioOffDelay1_0	7:4	GPIO[1] OFF Delay	...
		3:0	GPIO[0] OFF Delay	0xF: 3000ms
0x65	GpioPullUpDown7_4	7:6	GPIO[7] Pullup/down	Enables pullup/down resistors for GPI pins.
		5:4	GPIO[6] Pullup/down	00 : None (default)
		3:2	GPIO[5] Pullup/down	01 : Pullup
		1:0	GPIO[4] Pullup/down	10 : Pulldown
0x66	GpioPullUpDown3_0	7:6	GPIO[3] Pullup/down	11 : Reserved
		5:4	GPIO[2] Pullup/down	
		3:2	GPIO[1] Pullup/down	
		1:0	GPIO[0] Pullup/down	
0x67	GpioInterrupt7_4	7:6	GPI[7] Interrupt	Defines the GPI edge which will trigger INTB falling edge and exit Sleep/Doze modes if relevant.
		5:4	GPI[6] Interrupt	00 : None (default)
		3:2	GPI[5] Interrupt	01 : Rising
		1:0	GPI[4] Interrupt	10 : Falling
0x68	GpioInterrupt3_0	7:6	GPI[3] Interrupt	11 : Both
		5:4	GPI[2] Interrupt	
		3:2	GPI[1] Interrupt	



SX8634
 Low Power, Capacitive Button and Slider Touch Controller
 (12 sensors) with Enhanced LED Drivers and Proximity Sensing

ADVANCED COMMUNICATIONS & SENSING DATASHEET

GPIO Parameters												
Address	Name	Bits	Description									
		1:0	GPI[0] Interrupt									
0x69	GpioDebounce	7:0	<table border="1" style="width: 100%; border-collapse: collapse;"> <tr> <td style="width: 50%;">GPI[7] Debounce</td> <td rowspan="8" style="width: 50%; vertical-align: top;"> Enables the GPI debounce (done on 10 consecutive samples at 1ms). 0 : OFF (default) 1 : ON </td> </tr> <tr><td>GPI[6] Debounce</td></tr> <tr><td>GPI[5] Debounce</td></tr> <tr><td>GPI[4] Debounce</td></tr> <tr><td>GPI[3] Debounce</td></tr> <tr><td>GPI[2] Debounce</td></tr> <tr><td>GPI[1] Debounce</td></tr> <tr><td>GPI[0] Debounce</td></tr> </table>	GPI[7] Debounce	Enables the GPI debounce (done on 10 consecutive samples at 1ms). 0 : OFF (default) 1 : ON	GPI[6] Debounce	GPI[5] Debounce	GPI[4] Debounce	GPI[3] Debounce	GPI[2] Debounce	GPI[1] Debounce	GPI[0] Debounce
GPI[7] Debounce	Enables the GPI debounce (done on 10 consecutive samples at 1ms). 0 : OFF (default) 1 : ON											
GPI[6] Debounce												
GPI[5] Debounce												
GPI[4] Debounce												
GPI[3] Debounce												
GPI[2] Debounce												
GPI[1] Debounce												
GPI[0] Debounce												

Table 22 GPIO Parameters

Table 23 resumes the applicable SPM and I2C parameters for each GPIO mode.

		GPI	GPP	GPO
SPM	GpioMode	X	X	X
	GpioOutPwrUp		X ¹	X ²
	GpioAutoligh			X
	GpioPolarity		X	X
	GpioIntensityOn		X ¹	X
	GpioIntensityOff		X ¹	X
	GpioFunction		X	X
	GpioIncFactor			X
	GpioDecFactor			X
	GpioIncTime			X
	GpioDecTime			X
	GpioOffDelay			X
	GpioPullUpDown	X		
	GpioInterrupt	X		
GpioDebounce	X			
I2C	IrqSrc[4]	X		
	GpiStat	X		
	GpoCtrl			X ³
	GppPinId		X	
	GppIntensity		X ¹	

¹ At power up, GppIntensity of each GPP pin is initialized with GpioIntensityOn or GpioIntensityOff depending on GpioOutPwrUp corresponding bits value.

² Only if Autolight is OFF, else must be left to 0 (default value)

³ Only if Autolight is OFF, else ignored

Table 23 Applicable SPM/I2C Parameters vs. GPIO Mode



Low Power, Capacitive Button and Slider Touch Controller
 (12 sensors) with Enhanced LED Drivers and Proximity Sensing

ADVANCED COMMUNICATIONS & SENSING

DATASHEET

6 I2C INTERFACE

The I2C implemented on the SX8634 is compliant with:

- standard (100kb/s), fast mode (400kb/s)
- slave mode
- 7 bit address (default 0x2B). The default address can be changed in the NVM at address 0x04.

The host can use the I2C to read and write data at any time. The effective changes will be applied at the next processing phase (section 3.3).

Three types of registers are considered:

- status (read). These registers give information about the status of the capacitive buttons, slider, GPIOs, operation modes etc...
- control (read/write). These registers control the soft reset, operating modes, GPIOs and offset compensation.
- SPM gateway (read/write). These registers are used for the communication between host and the SPM. The SPM gateway communication is done typically at power up and is not supposed to be changed when the application is running. The SPM needs to be re-stored each time the SX8634 is powered down. The SPM can be stored permanently in the NVM memory of the SX8634. The SPM gateway communication over the I2C at power up is then not required.

The I2C will be able to read and write from a start address and then perform read or writes sequentially, and the address increments automatically.

The supported I2C access formats are described in the next sections.

6.1 I2C Write

The format of the I2C write is given in Figure 52.

After the start condition [S], the slave address (SA) is sent, followed by an eighth bit ('0') indicating a Write. The SX8634 then Acknowledges [A] that it is being addressed, and the Master sends an 8 bit Data Byte consisting of the SX8634 Register Address (RA). The Slave Acknowledges [A] and the master sends the appropriate 8 bit Data Byte (WD0). Again the Slave Acknowledges [A]. In case the master needs to write more data, a succeeding 8 bit Data Byte will follow (WD1), acknowledged by the slave [A]. This sequence will be repeated until the master terminates the transfer with the Stop condition [P].

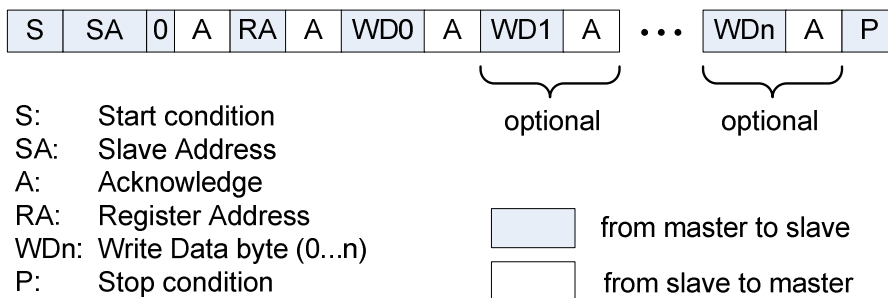

Figure 52 I2C write

The register address is incremented automatically when successive register data (WD1...WDn) is supplied by the master.



ADVANCED COMMUNICATIONS & SENSING DATASHEET

6.2 I2C read

The format of the I2C read is given in Figure 53.

After the start condition [S], the slave address (SA) is sent, followed by an eighth bit ('0') indicating a Write. The SX8634 then Acknowledges [A] that it is being addressed, and the Master responds with an 8 bit Data consisting of the Register Address (RA). The Slave Acknowledges [A] and the master sends the Repeated Start Condition [Sr]. Once again, the slave address (SA) is sent, followed by an eighth bit ('1') indicating a Read.

The SX8634 responds with an Acknowledge [A] and the read Data byte (RD0). If the master needs to read more data it will acknowledge [A] and the SX8634 will send the next read byte (RD1). This sequence can be repeated until the master terminates with a NACK [N] followed by a stop [P].

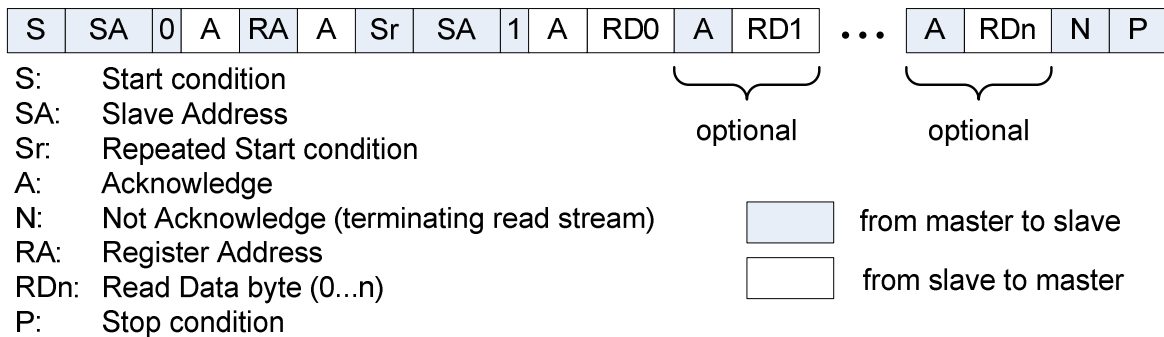

Figure 53 I2C read



SX8634
 Low Power, Capacitive Button and Slider Touch Controller
 (12 sensors) with Enhanced LED Drivers and Proximity Sensing

ADVANCED COMMUNICATIONS & SENSING DATASHEET

6.3 I2C Registers Overview

Address	Name	R/W	Description
0x00	IrqSrc	read	Interrupt Source
0x01	CapStatMsb	read	Slider/Button Status MSB
0x02	CapStatLsb	read	Button Status LSB
0x03	SldPosMsb	read	Slider Position MSB
0x04	SldPosLsb	read	Slider Position LSB
0x05	Reserved		
0x06	Reserved		
0x07	GpiStat	read	GPI Status
0x08	SpmStat	read	SPM Status
0x09	CompOpMode	read/write	Compensation and Operating Mode
0x0A	GpoCtrl	read/write	GPO Control
0x0B	GppPinId	read/write	GPP Pin Selection
0x0C	GppIntensity	read/write	GPP Intensity
0x0D	SpmCfg	read/write	SPM Configuration
0x0E	SpmBaseAddr	read/write	SPM Base Address
0x0F	Reserved		
0xAC	SpmKeyMsb	read/write	SPM Key MSB
0xAD	SpmkeyLsb	read/write	SPM Key LSB
0xB1	SoftReset	read/write	Software Reset

Table 24 I2C Registers Overview



Low Power, Capacitive Button and Slider Touch Controller
 (12 sensors) with Enhanced LED Drivers and Proximity Sensing

ADVANCED COMMUNICATIONS & SENSING DATASHEET

6.4 Status Registers

Address	Name	Bits	Description
0x00	IrqSrc	7	Reserved
		6	NVM burn interrupt flag
		5	SPM write interrupt flag
		4	GPI interrupt flag
		3	Slider interrupt flag
		2	Buttons interrupt flag
		1	Compensation interrupt flag
		0	Operating Mode interrupt flag

Table 25 Interrupt Source

The delay between the actual event and the flags indicating the interrupt source may be one scan period.

IrqSrc[6] is set once NVM burn procedure is completed.

IrqSrc[5] is set once SPM write is effective.

IrqSrc[4] is set if a GPI edge as programmed in GpioInterrupt occurred. GpiStat shows the detailed status of the GPI pins.

IrqSrc[3] is set if a Slider event occurred (touch, release, move high, move low or position change) . CapStatMsb, SldPosMsb and SldPosLsb show the detailed status of the Slider.

IrqSrc[2] is set if a Button event occurred (touch or release if enabled). CapStatMsb and CapStatLsb show the detailed status of the Buttons.

IrqSrc[1] is set once compensation procedure is completed either through automatic trigger or via host request.

IrqSrc[0] is set when actually entering Active or Doze mode either through automatic wakeup or via host request. CompOpmode shows the current operation mode.



SX8634

Low Power, Capacitive Button and Slider Touch Controller
 (12 sensors) with Enhanced LED Drivers and Proximity Sensing

ADVANCED COMMUNICATIONS & SENSING DATASHEET

Address	Name	Bits	Description
0x01	CapStatMsb	7	Reserved
		6	Slider Move High
		5	Slider Move Low
		4	Slider Touched
		3	Button 11 Touched
		2	Button 10 Touched
		1	Button 9 Touched
		0	Button 8 Touched
0x02	CapStatLsb	7	Button 7 Touched
		6	Button 6 Touched
		5	Button 5 Touched
		4	Button 4 Touched
		3	Button 3 Touched
		2	Button 2 Touched
		1	Button 1 Touched
		0	Button 0 Touched

Table 26 Slider, Button status MSB/LSB

Address	Name	Bits	Description
0x03	SldPosMsb	7:0	Slider Position[15:8]
0x04	SldPosLsb	7:0	Slider Position[7:0]

Table 27 Slider position MSB/LSB

Address	Name	Bits	Description
0x07	GpiStat	7:0	GPI[7:0] Status Status of each individual GPI pin 0: Low 1: High Bits of non-GPI pins are set to 0.

Table 28 I2C GPI status



SX8634
 Low Power, Capacitive Button and Slider Touch Controller
 (12 sensors) with Enhanced LED Drivers and Proximity Sensing

ADVANCED COMMUNICATIONS & SENSING DATASHEET

Address	Name	Bits	Description
0x08	SpmStat	7:4	reserved
		3	NvmValid Indicates if the current NVM is valid. 0: No – QSM is used 1: Yes – NVM is used
		2:0	NvmCount Indicates the number of times NVM has been burned: 0: None – QSM is used (default) 1: Once – NVM is used if NvmValid = 1, else QSM. 2: Twice – NVM is used if NvmValid = 1, else QSM. 3: Three times – NVM is used if NvmValid = 1, else QSM. 4: More than three times – QSM is used

Table 29 I2C SPM status



SX8634
 Low Power, Capacitive Button and Slider Touch Controller
 (12 sensors) with Enhanced LED Drivers and Proximity Sensing

ADVANCED COMMUNICATIONS & SENSING DATASHEET

6.5 Control Registers

Address	Name	Bits	Description
0x09	CompOpMode	7:3	Reserved*, write only '0000'
		2	Compensation Indicates/triggers compensation procedure 0: Compensation completed (default) 1: read -> compensation running ; write -> trigger compensation
		1:0	Operating Mode Indicates/programs** operating mode 00: Active mode (default) 01: Doze mode 10: Sleep mode 11: Reserved

Table 30 I2C compensation, operation modes

* The reading of these reserved bits will return varying values.

** After the operating mode change (Active/Doze) the host should wait for INTB or 300ms before performing any I2C read access.

Address	Name	Bits	Description
0x0A	GpoCtrl	7:0	GpoCtrl[7:0] Triggers ON/OFF state of GPOs when Autolight is OFF 0: OFF (ie go to IntensityOff) 1: ON (ie go to IntensityOn) Default is set by SPM parameter GpioOutPwrUp Bits of non-GPO pins are ignored.

Table 31 I2C GPO Control



SX8634
 Low Power, Capacitive Button and Slider Touch Controller
 (12 sensors) with Enhanced LED Drivers and Proximity Sensing

ADVANCED COMMUNICATIONS & SENSING DATASHEET

Address	Name	Bits	Description
0x0B	GppPinId	7:3	Reserved, write only '00000'
		2:0	GPP Pin Identifier Defines the GPP pin to which the GppIntensity is assigned for the following read/write operations 0x0 = GPP0 (default) 0x1 = GPP1 ... 0x7 = GPP7 GPPx refers to pin GPIOx configured as GPP

Table 32 I2C GPP Pin Identifier

Address	Name	Bits	Description
0x0C	GppIntensity	7:0	Defines the intensity index of the GPP pin selected in GppPinId 0x00: 0 0x01: 1 ... 0xFF: 255 Reading returns the intensity index of the GPP pin selected in GppPinId. Default value is IntensityOn or IntensityOff depending on GpioOutPwrUp.

Table 33 I2C GPP Intensity

Address	Name	Bits	Description
0xB1	SoftReset	7:0	Writing 0xDE followed by 0x00 will reset the chip.

Table 34 I2C Soft Reset



Low Power, Capacitive Button and Slider Touch Controller
 (12 sensors) with Enhanced LED Drivers and Proximity Sensing

ADVANCED COMMUNICATIONS & SENSING DATASHEET

6.6 SPM Gateway Registers

The SX8634 I2C interface offers two registers for exchanging the SPM data with the host.

- SpmCfg
- SpmBaseAddr

Address	Name	Bits	Description
0x0D	SpmCfg	7:6	00: Reserved
		5:4	Enables I2C SPM mode 00: OFF (default) 01: ON 10: Reserved 11: Reserved
		3	Defines r/w direction of SPM 0: SPM write access (default) 1: SPM read access
		2:0	000: Reserved

Table 35 SPM access configuration

Address	Name	Bits	Description
0x0E	SpmBaseAddr	7:0	SPM Base Address (modulo 8). The lowest address is 0x00 (default). The highest address is 0x78.

Table 36 SPM Base Address

The exchange of data, read and write, between the host and the SPM is always done in bursts of eight bytes. The base address of each burst of eight bytes is a modulo 8 number, starting at 0x00 and ending at 0x78.

The registers SpmKeyMsb and SpmKeyLsb are required for NVM programming as described in section 6.7.

Address	Name	Bits	Description
0xAC	SpmKeyMsb	7:0	SPM to NVM burn Key MSB Unlock requires writing data: 0x62

Table 37 SPM Key MSB

Address	Name	Bits	Description
0xAD	SpmKeyLsb	7:0	SPM to NVM burn Key LSB Unlock requires writing data: 0x9D

Table 38 SPM Key LSB



SEMTECH

Low Power, Capacitive Button and Slider Touch Controller
 (12 sensors) with Enhanced LED Drivers and Proximity Sensing

ADVANCED COMMUNICATIONS & SENSING DATASHEET

6.6.1 SPM Write Sequence

The SPM write can be done in any mode (Active, Doze, Sleep). Writing the SPM in Sleep is useful to avoid potential transient behaviors.

The SPM must always be written in blocks of 8 bytes. The sequence is described below:

1. Set the I2C in SPM mode by writing "01" to SpmCfg[5:4] and SPM write access by writing '0' to SpmCfg[3].
2. Write the SPM base address to SpmBaseAddr (The base address needs to be a value modulo 8).
3. Write the eight consecutive bytes to I2C address 0, 1, 2, ...7
4. Terminate by writing "000" to SpmCfg[5:3].

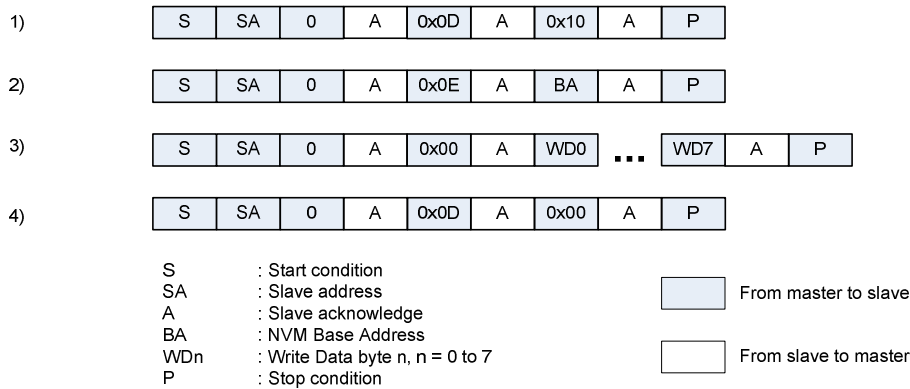

Figure 54: SPM Write Sequence

The complete SPM can be written by repeating 16 times the cycles shown in Figure 54 using base addresses 0x00, 0x08, 0x10, ..., 0x70, 0x78. Between each sequence the host should wait for INTB (Active/Doze) or 30ms in Sleep.

In Active or Doze mode, once the SPM write sequence is actually applied, the INTB pin will be asserted and IrqSrc[5] set. In Sleep mode the SPM write can be actually applied with a delay of 30ms.

The host clears the interrupt and IrqSrc[5] by reading the IrqSrc register.



ADVANCED COMMUNICATIONS & SENSING DATASHEET

6.6.2 SPM Read Sequence

The SPM read can be done in any mode (Active, Doze, Sleep).

The SPM must always be read in blocks of 8 bytes. The sequence is described below:

1. Set the I2C in SPM mode by writing "01" to SpmCfg[5:4] and SPM read access by writing '1' to SpmCfg[3].
2. Write the SPM base address to SpmBaseAddr (The base address needs to be a value modulo 8).
3. Read the eight consecutive bytes from I2C address 0, 1, 2, ...7
4. Terminate by writing "000" to SpmCfg[5:3].

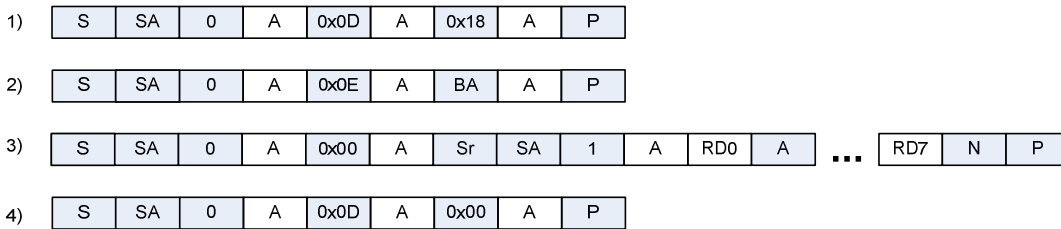

S, Sr : Start condition
 SA : Slave address
 A : Slave acknowledge From master to slave
 N : Not Acknowledge (terminates read stream)
 BA : NVM Base Address From slave to master
 RDn : Read Data byte n, n = 0 to 7
 P : Stop condition

Figure 55: SPM Read Sequence

The complete SPM can be read by repeating 16 times the cycles shown in Figure 55 using base addresses 0x00, 0x08, 0x10, ..., 0x70, 0x78.



Low Power, Capacitive Button and Slider Touch Controller
 (12 sensors) with Enhanced LED Drivers and Proximity Sensing

ADVANCED COMMUNICATIONS & SENSING DATASHEET

6.7 NVM burn

The content of the SPM can be copied permanently (burned) into the NVM to be used as the new default parameters. The burning of the NVM can be done up to three times and must be done only when the SPM is completely written with the desired data. The NVM burn must be done in Active or Doze mode. Once the NVM burn process is terminated IrqSrc[6] will be set and INTB asserted. After a reset the burned NVM parameters will be copied into the SPM.

The number of times the NVM has been burned can be monitored by reading NvmCount from the I2C register SpmStat[2:0].

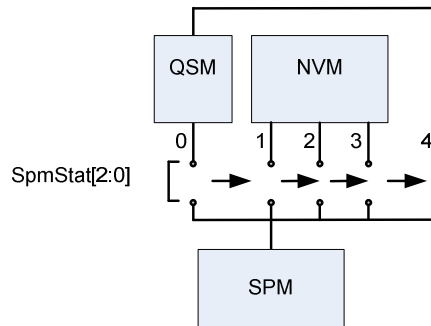

Figure 56 Simplified Diagram NvmCount

Figure 56 shows the simplified diagram of the NVM counter. The SX8634 is delivered with empty NVM and NvmCount set to zero. The SPM points to the QSM. Each NVM burn will increase the NvmCount. At the fourth NVM burn the SX8634 switches definitely to the QSM.

The burning of the SPM into the NVM is done by executing a special sequence of four I2C commands.

- | | |
|--|------------------------------------|
| 1. Write the data 0x62 to the I2C register I2CKeyMsb. | Terminate the I2C write by a STOP. |
| 2. Write the data 0x9D to the I2C register I2CKeyLsb. | Terminate the I2C write by a STOP. |
| 3. Write the data 0xA5 to the I2C register I2CSpmBaseAddr. | Terminate the I2C write by a STOP. |
| 4. Write the data 0x5A to the I2C register I2CSpmBaseAddr. | Terminate the I2C write by a STOP. |

This is illustrated in Figure 57.

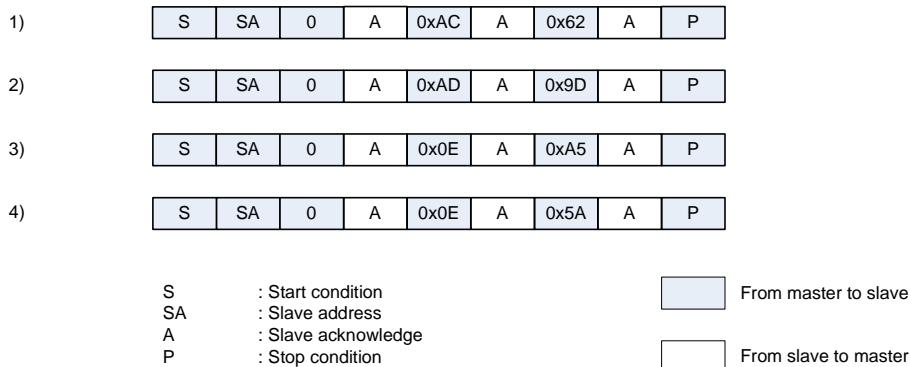

Figure 57: NVM burn procedure

SX8634



SEMTECH

Low Power, Capacitive Button and Slider Touch Controller
 (12 sensors) with Enhanced LED Drivers and Proximity Sensing

ADVANCED COMMUNICATIONS & SENSING

DATASHEET

7 APPLICATION INFORMATION

7.1 Typical Application Schematic

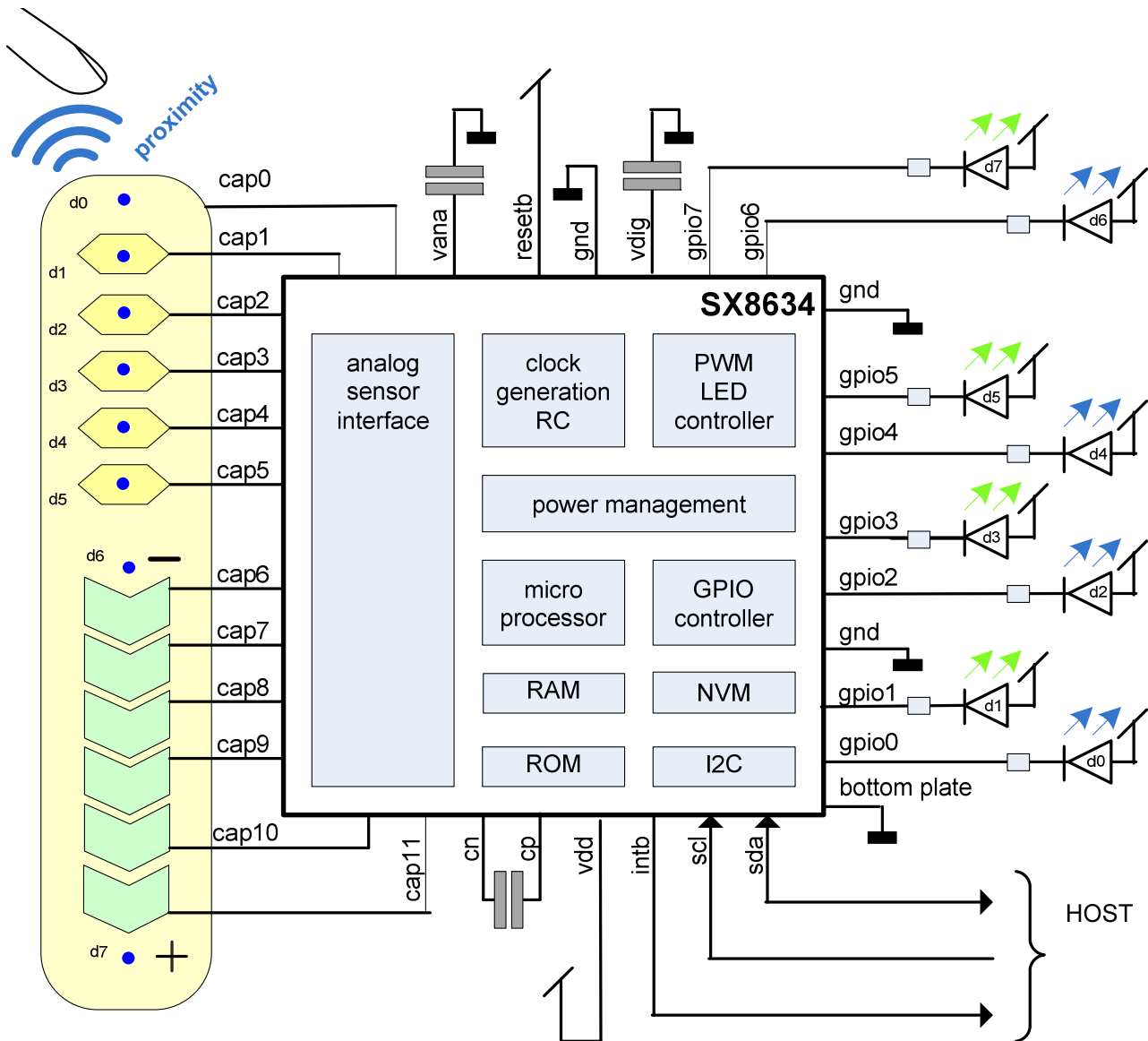

Figure 58 Typical Application

SX8634



Low Power, Capacitive Button and Slider Touch Controller
 (12 sensors) with Enhanced LED Drivers and Proximity Sensing

ADVANCED COMMUNICATIONS & SENSING DATASHEET

7.2 Example of Touch+Proximity Module

7.2.1 Overview

To demonstrate the proximity sensing feature of the SX863x family, a module has been designed and is illustrated in figure below.

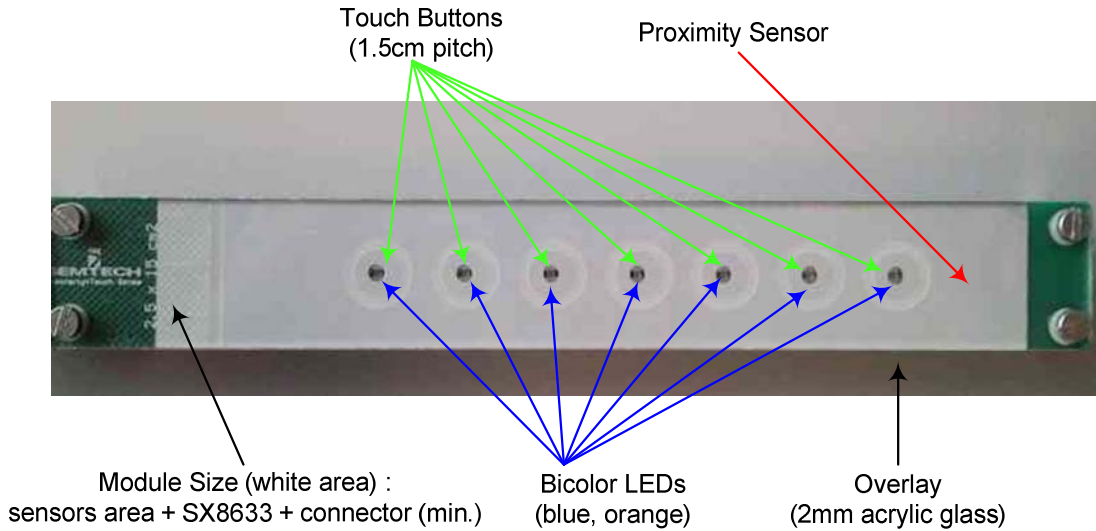

Figure 59 Touch+Proximity Module Overview

The touch button controller is running in stand-alone (ie without host) and uses the Autolight mode to turn LEDs ON/OFF accordingly to the touch buttons and proximity sensing status.

7.2.2 Operation

Module operation can be seen as 5 steps which are described in figure below



Figure 60 Touch+Proximity Module Operation

Notes:

- For better user experience, bicolor LEDs have been used here but one could decide to design a module with normal unicolor LEDs. In this case, step 3 above would simply consist in a higher (blue) intensity for the LED of the button touched.
- For obvious demonstration purposes the overlay used here is transparent but in typical applications (TV, Monitor, Set-top box, etc) the overlay would be opaque enough so that when LEDs are OFF (ie no proximity detected) the PCB is not visible to the user.

7.2.3 Performance

The proximity sensing distance of detection has been measured in these conditions:

- CapProxEnable = ON

SX8634



Low Power, Capacitive Button and Slider Touch Controller
 (12 sensors) with Enhanced LED Drivers and Proximity Sensing

ADVANCED COMMUNICATIONS & SENSING DATASHEET

- CapSensitivity = 7 (Max)
- CapThreshold = 300
- Board main supplied and placed vertically ie same orientation as hand/finger
- Finger pointing center button

The results obtained are provided in table below:

	Distance of Detection
Palm	~10cm
Finger (natural position)	~6cm
Orthogonal finger (worst case)	~4cm

Table 39 Proximity Sensing Distance of Detection

7.2.4 Schematics

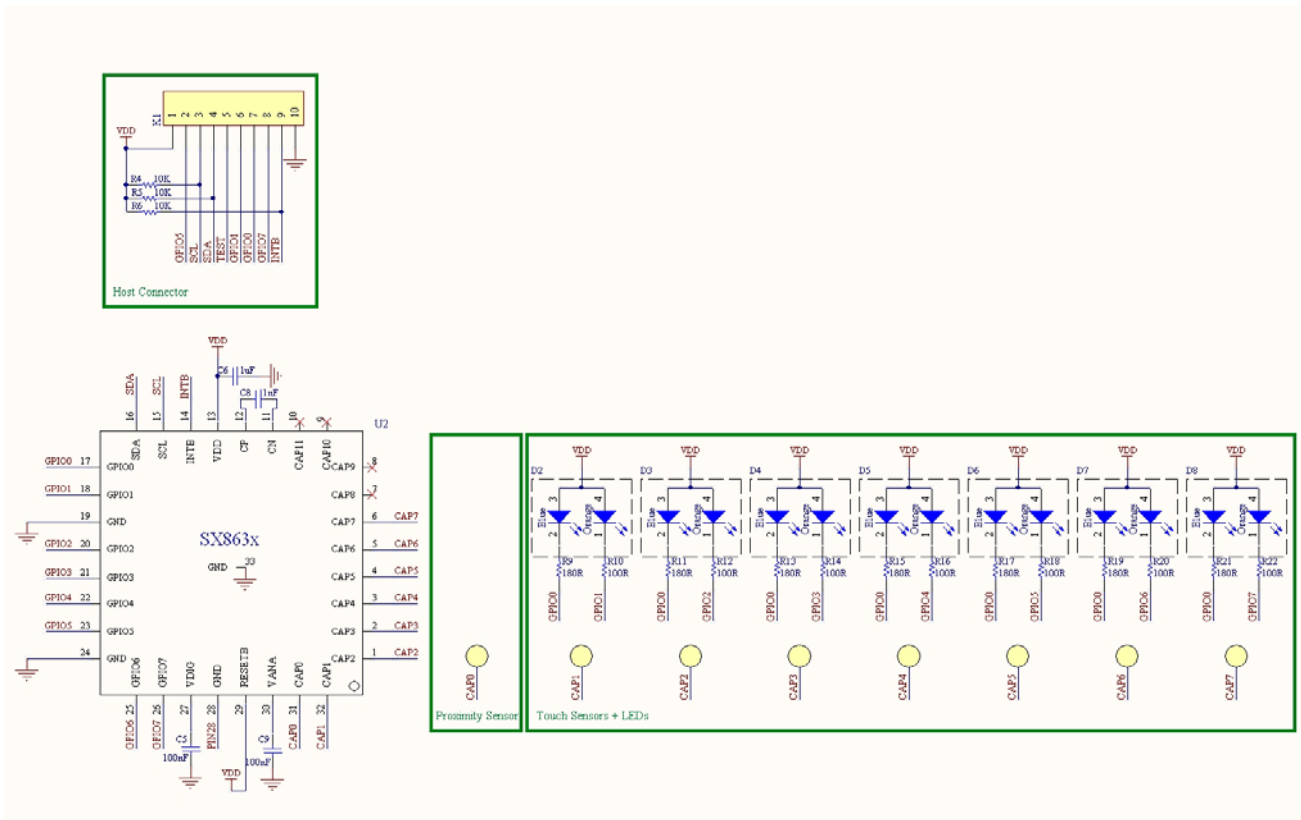

Figure 61 Touch+Proximity Module Schematics



Low Power, Capacitive Button and Slider Touch Controller
(12 sensors) with Enhanced LED Drivers and Proximity Sensing

ADVANCED COMMUNICATIONS & SENSING

DATASHEET

7.2.5 Layout

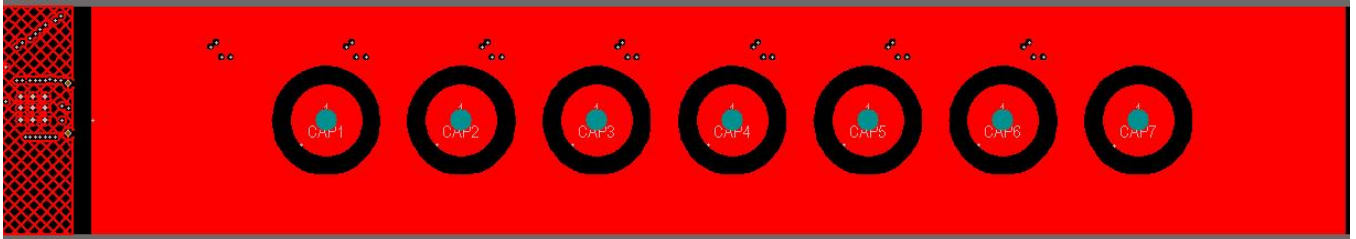

Figure 62 Touch+Proximity Module Layout - Top

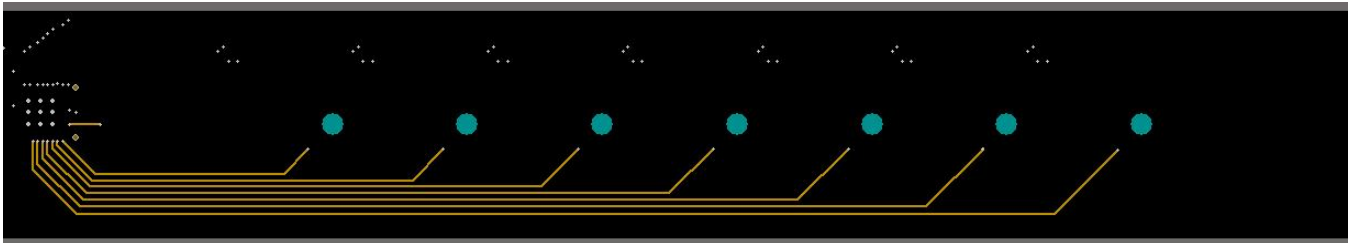

Figure 63 Touch+Proximity Module Layout - Mid1

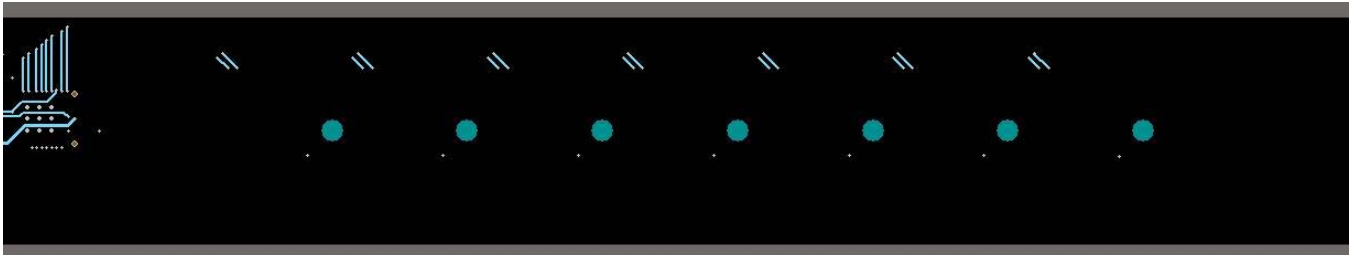

Figure 64 Touch+Proximity Module Layout - Mid2

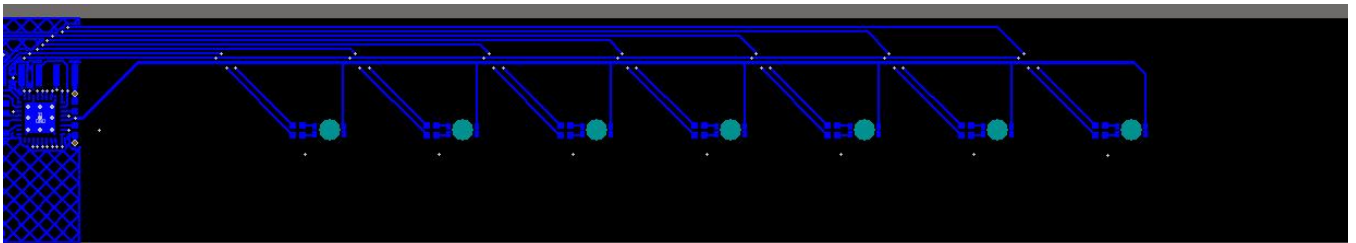

Figure 65 Touch+Proximity Module Layout - Bottom



SEMTECH

SX8634
Low Power, Capacitive Button and Slider Touch Controller
(12 sensors) with Enhanced LED Drivers and Proximity Sensing

ADVANCED COMMUNICATIONS & SENSING

DATASHEET

8 REFERENCES

[1] Capacitive Touch Sensing Layout guidelines on www.semtech.com

SX8634



SEMTECH

Low Power, Capacitive Button and Slider Touch Controller
 (12 sensors) with Enhanced LED Drivers and Proximity Sensing

ADVANCED COMMUNICATIONS & SENSING

DATASHEET

9 PACKAGING INFORMATION

9.1 Package Outline Drawing

SX8634 is assembled in a MLPQ-W32 package as shown in Figure 66.

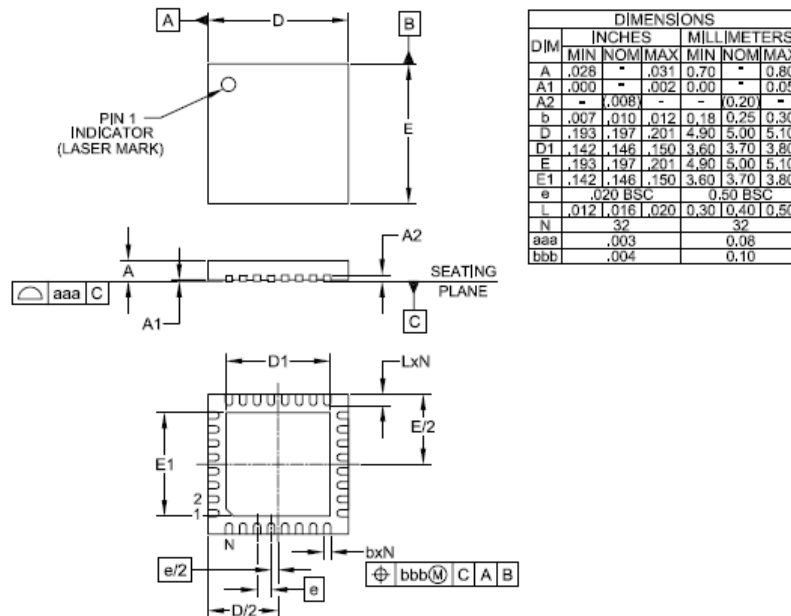

- NOTES:
 1. CONTROLLING DIMENSIONS ARE IN MILLIMETERS (ANGLES IN DEGREES).
 2. COPLANARITY APPLIES TO THE EXPOSED PAD AS WELL AS THE TERMINALS.

Figure 66 Package Outline Drawing

9.2 Land Pattern

The land pattern of MLPQ-W32 package, 5 mm x 5 mm is shown in Figure 67.

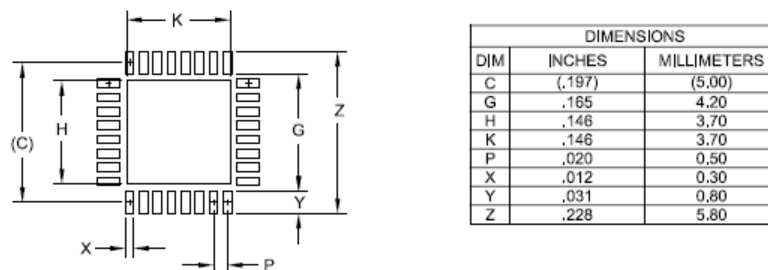

- NOTES:
 1. CONTROLLING DIMENSIONS ARE IN MILLIMETERS (ANGLES IN DEGREES).
 2. THIS LAND PATTERN IS FOR REFERENCE PURPOSES ONLY. CONSULT YOUR MANUFACTURING GROUP TO ENSURE YOUR COMPANY'S MANUFACTURING GUIDELINES ARE MET.
 3. THERMAL VIAS IN THE LAND PATTERN OF THE EXPOSED PAD SHALL BE CONNECTED TO A SYSTEM GROUND PLANE. FAILURE TO DO SO MAY COMPROMISE THE THERMAL AND/OR FUNCTIONAL PERFORMANCE OF THE DEVICE.
 4. SQUARE PACKAGE - DIMENSIONS APPLY IN BOTH "X" AND "Y" DIRECTIONS.

Figure 67 Land Pattern

**SEMTECH**Low Power, Capacitive Button and Slider Touch Controller
(12 sensors) with Enhanced LED Drivers and Proximity Sensing**SX8634****ADVANCED COMMUNICATIONS & SENSING****DATASHEET**

© Semtech 2010

All rights reserved. Reproduction in whole or in part is prohibited without the prior written consent of the copyright owner. The information presented in this document does not form part of any quotation or contract, is believed to be accurate and reliable and may be changed without notice. No liability will be accepted by the publisher for any consequence of its use. Publication thereof does not convey nor imply any license under patent or other industrial or intellectual property rights. Semtech assumes no responsibility or liability whatsoever for any failure or unexpected operation resulting from misuse, neglect improper installation, repair or improper handling or unusual physical or electrical stress including, but not limited to, exposure to parameters beyond the specified maximum ratings or operation outside the specified range.

SEMTECH PRODUCTS ARE NOT DESIGNED, INTENDED, AUTHORIZED OR WARRANTED TO BE SUITABLE FOR USE IN LIFE-SUPPORT APPLICATIONS, DEVICES OR SYSTEMS OR OTHER CRITICAL APPLICATIONS. INCLUSION OF SEMTECH PRODUCTS IN SUCH APPLICATIONS IS UNDERSTOOD TO BE UNDERTAKEN SOLELY AT THE CUSTOMER'S OWN RISK. Should a customer purchase or use Semtech products for any such unauthorized application, the customer shall indemnify and hold Semtech and its officers, employees, subsidiaries, affiliates, and distributors harmless against all claims, costs damages and attorney fees which could arise.

Notice: All referenced brands, product names, service names and trademarks are the property of their respective owners.

Contact Information

Semtech Corporation
Advanced Communications and Sensing Products Division
200 Flynn Road, Camarillo, CA 93012
Phone: (805) 498-2111 Fax: (805) 498-3804