



Excellent Integrated System Limited

Stocking Distributor

Click to view price, real time Inventory, Delivery & Lifecycle Information:

[Essentra Components \(formerly Richco, Inc.\)](#)
[WHC-125-01](#)

For any questions, you can email us directly:

sales@integrated-circuit.com

NYLON 6/6 (RMS-01) COLOR: NATURAL PART NO.	"A" REF HOLDING DIAMETER	"B"	"C"	"D"	"E" REF.
WHC-125-01	1/8 (3.2)	.05 (1.3)	.33 (8.4)	.23 (5.8)	.75 (19.1)
WHC-250-01	1/4 (6.4)	.04 (1.0)	.40 (10.2)	.25 (6.4)	.83 (21.1)
WHC-375-01	3/8 (9.5)	.05 (1.3)		.19 (4.8)	
WHC-500-01	1/2 (12.7)	.07 (1.8)	.50 (12.7)	.25 (6.4)	1-5/32 (29.4)
WHC-625-01	5/8 (15.9)	.08 (2.0)		.19 (4.8)	1-1/8 (28.6)
WHC-750-01	3/4 (19.1)	.09 (2.2)			1-9/32 (32.5)
WHC-1000-01	1 (25.4)	.09 (2.2)	.10 (2.5)		1-17/32 (38.9)
WHC-1500-01	1-1/2 (38.1)				2-1/8 (53.9)

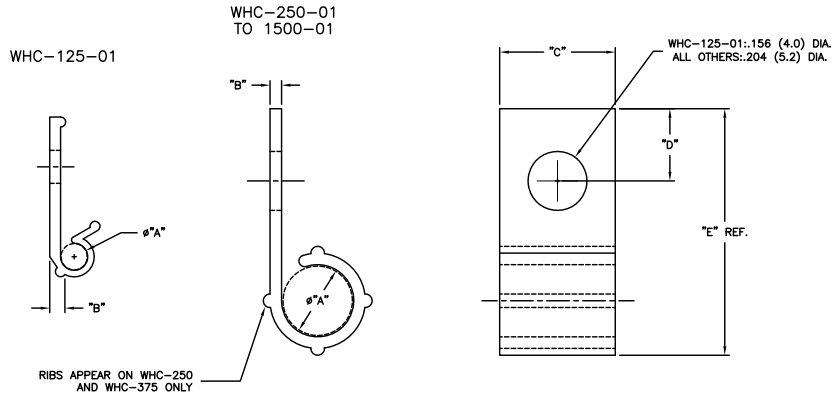

NOTES:

- MATERIAL: FLAME RETARDANT (RMS-19), COLOR NATURAL, AVAILABLE BY SPECIAL ORDER. TO ORDER, REPLACE "-01" WITH "-19".
- MATERIAL: UV STABILIZED NYLON (RMS-46), COLOR BLACK, AVAILABLE BY SPECIAL ORDER. TO ORDER, REPLACE "-01" WITH "-UVB"

TITLE: WIRE HARNESS CLIP		DWG IN IN (MM)		FINAL	
TOLERANCES UNLESS NOTED .XX=±.010 .XXX=±.005 FRAC=1/64 ANG=1°		FILE # WHC	DWN: P.B.	APP:	PART #
H SEE CO 200664 FOR CHANGES SK 04.27.11		MATERIAL: SEE TABLE		DT: 05-02-94 DT:	
G SEE CO 200091 FOR CHANGES SK 12.18.07		RE: RICHCO, INC.		RICHCO INC.	
F SEE ECN #1358 FOR CHANGES SK 08.24.07		RICHCO, INC.		PO BOX 804238, CHICAGO, 60680	
- SEE ENGINEERING FOR REV A-E		RICHCO, INC.		(773) 539-4060	
REV DESCRIPTION ENGR DATE		SEE TABLE		PRINT TYPE CA	