

Excellent Integrated System Limited

Stocking Distributor

Click to view price, real time Inventory, Delivery & Lifecycle Information:

[NKK Switches](#)
[IS15ABDP4EG](#)

For any questions, you can email us directly:
sales@integrated-circuit.com

IS15ABDP4EG

Version (1)



DISTINCTIVE CHARACTERISTICS

Enhanced LED Illumination with:

- Broad and even light distribution
- Consistent bright backlighting
- Lower energy consumption

Programmable LC Display

Yellow/Blue LED Backlighting

Rubber Dome

Epoxy Sealed Straight PC Terminals

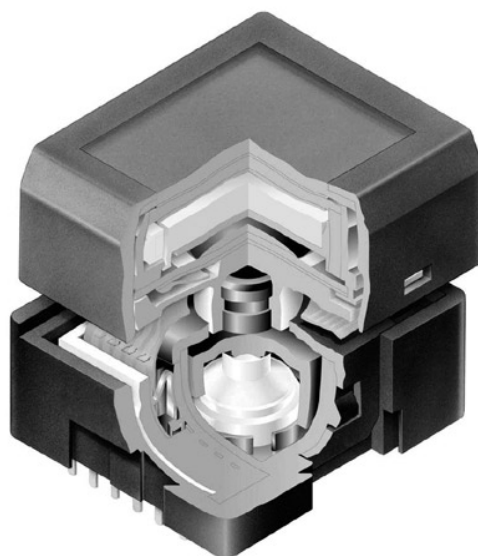

Programmable to display graphics, alphanumeric characters, and animated sequences.

Integrated liquid crystal display provides wide viewing angle with high contrast and clarity.

Wide viewing area 15.0mm x 10.8mm (horizontal x vertical) at 36 x 24 pixels.

Dome gives crisp tactile feedback to positively indicate circuit transfer.

High reliability and long life of one million actuations minimum.

Epoxy sealed terminals prevent entry of solder flux and other contaminants.

Optional accessories available to enhance panel design and simplify production process.

SWITCH SPECIFICATIONS

Circuit	SPST normally open
Electrical Capacity (Resistive Load)	100mA @ 12V DC
Contact Resistance	200 milliohms maximum @ 20mV 10mA
Insulation Resistance	100 megohms minimum @ 100V DC
Dielectric Strength	125V AC for 1 minute minimum
Mechanical Endurance	1,000,000 operations minimum
Electrical Endurance	1,000,000 operations minimum
Operating Force	2.2 ± 0.5 Newtons
Total Travel	1.8mm (.071")
Operating Temperature Range	0°C ~ +40°C (+32°F ~ +104°F); contact factory for wide temperature range options
Storage Temperature Range	-10°C ~ +60°C (+14°F ~ +140°F); contact factory for wide temperature range options

SMARTSWITCH™



LCD SPECIFICATIONS

Characteristics of Display

Display Operation Mode	STN negative
Display Condition	Transflective with built-in LED backlight
Viewing Angle	Adjustable
Driving Method	1/24 duty, 1/5 bias (built-in driving circuit)
Viewing Area	15.0mm x 10.8mm (horizontal x vertical)
Pixel Format	36 x 24 dots (horizontal x vertical)
Pixel Size	0.36mm x 0.36mm (horizontal x vertical)
Backlight LED	Yellow/Blue



Yellow/Blue Bicolor LED
with Blue LCD Mode

Absolute Maximum Ratings (Temperature at 25°C)

Items	Symbols	Ratings
Supply Voltage for Logics	V_{DD}	-0.3V to +7.0V
Supply Voltage for LCD	V_{LC}	-0.3V to +12.0V
Input Voltage	V_I	-0.3V to $V_{DD}+0.3V$
Output Voltage	V_O	-0.3V to $V_{DD}+0.3V$

Recommended Operating Conditions (Temperature at 25°C)

Items	Symbols	Minimum	Typical	Maximum
Supply Voltage for Logics	V_{DD}	4.5V	5.0V	5.5V
Supply Voltage Blue	V_{LC}	—	7.5V	—
Input Voltage	V_I	0V	—	V_{DD}
Driving Frequency	f_{FLM}	—	64Hz	—

DC Characteristics of LCD Drive IC (Temperature at 0°C to 40°C and $V_{DD} = 5.0V \pm 10\%$)

Items	Symbols	Test Conditions	Minimum	Typical	Maximum	Unit
High Level Input Voltage	V_{IH}		0.7 V_{DD}		V_{DD}	V
Low Level Input Voltage	V_{IL}		0		0.3 V_{DD}	V
High Level Input Leakage Current	I_{LH}	$V_I = V_{DD}$			10	μA
Low Level Input Leakage Current	I_{LIL}	$V_I = 0V$			-10	μA
High Level Output Voltage	V_{OH}	$I_{OH} = -500\mu A$	$V_{DD} - 0.5$			V
Low Level Output Voltage	V_{OL}	$I_{OL} = 500\mu A$			0.5	V
High Level Output Leakage Current	I_{LOH}	$V_O = V_{DD}$			10	μA
Low Level Output Leakage Current	I_{LOL}	$V_O = 0V$			-10	μA
Supply Current	I_{DD}	$f_{SCP} = 1.0MHz$			500	μA
LCD Drive Current	I_{LC}	$f_{LP} = 2.4kHz$ $V_{LC} = 7.3V \sim 7.5V$		500	2,000	μA

Timing Characteristics of LCD Drive IC

(Temperature at 0°C to 40°C and $V_{DD} = 5.0V \pm 10\%$)

Items	Symbols	Minimum	Maximum
Clock Operation Frequency	f_{SCP}		6.0MHz
Latch Pulse Frequency	f_{LP}		50kHz
Clock High Level Pulse Width	t_{CWH}	70ns	
Clock Low Level Pulse Width	t_{CWL}	70ns	
Data Setup Time	t_{DSD}	45ns	
Data Hold Time	t_{DHD}	50ns	
Data Output Delay Time	t_{PDO}		25ns
Latch Setup Time	t_{DSL}	50ns	
Latch Hold Time	t_{DHL}	50ns	
Latch High Level Width	t_{LWH}	200ns	
FLM Setup Time	t_{DSF}	50ns	
FLM Hold Time	t_{DHF}	50ns	
SCP, LP Rise/Fall Time	t_r/t_f		15ns

Timing Diagram

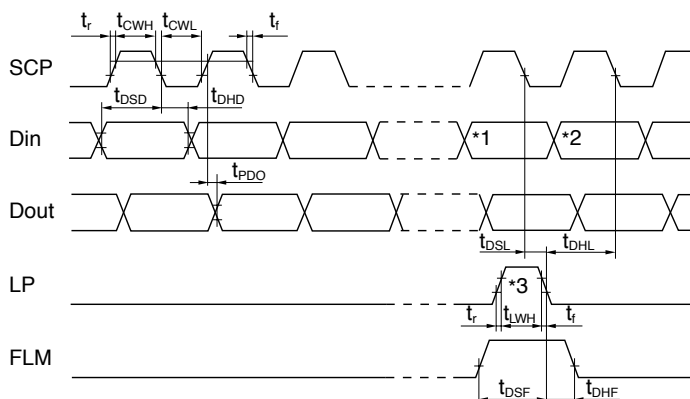

- *1 Last data on first line
- *2 Beginning data on second line
- *3 Location of LP signal on first line

SMARTSWITCH™



BLOCK DIAGRAM & PIN CONFIGURATIONS

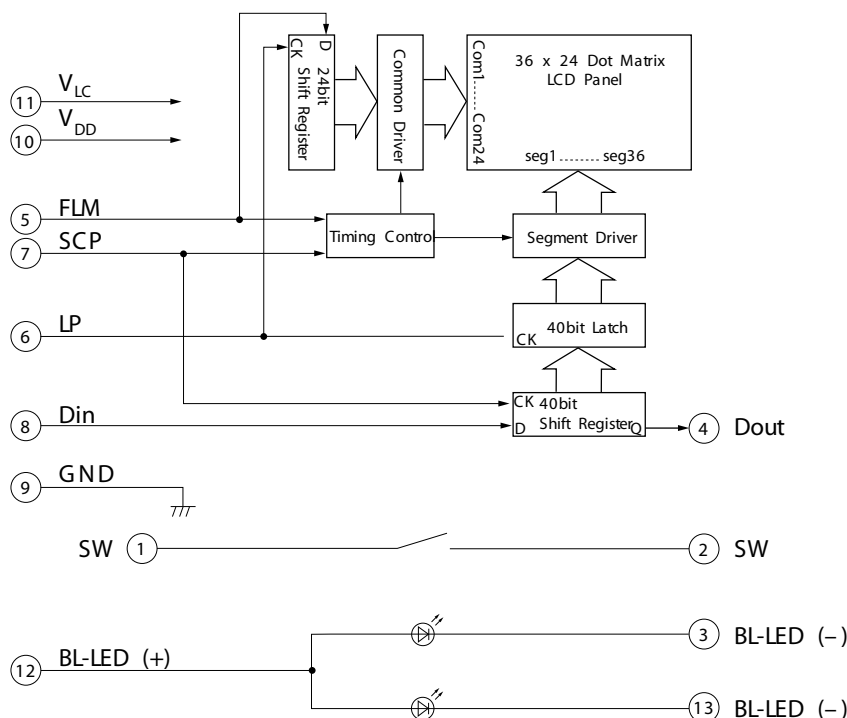

Pin No.	Symbol	Name	Function
①	SW	Terminal of Switch	Normally open
②	SW	Terminal of Switch	Normally open
③	BL-LED (-)	Terminal of Backlight LED	Cathode: yellow
④	Dout	Data Output	Display serial output. Can be used to connect to Din of the next SMARTSWITCH. As a result, many SMARTSWITCHES can be controlled with one clock and data signal.
⑤	FLM	First Line Marker	The marking signal for the first line data of LCD display. The first line of LCD will be selected by the falling edge of LP signal during the high level (FLM).
⑥	LP	Latch Pulse	Line data latch pulse will latch content of internal 40-bit shift register at falling edge for one line of display. LP will also increment the display line by one.
⑦	SCP	Serial Clock Pulse	Clock used by 40-bit internal shift register of the switch, shifting the display data bit presented at Din at falling edge.
⑧	Din	Data Input	Display serial data bit. Note: to map the display data, because of the difference between the number of internal shift register data (40) and the single line of LCD pixels (36), the first four bits of data shifted will be dummy bits.
⑨	GND	Ground	
⑩	V _{DD}	Power	Power source for logic circuit
⑪	V _{Lc}	Power	Power source for LCD drive
⑫	BL-LED (+)	Terminal of Backlight LED	Anode for common
⑬	BL-LED (-)	Terminal of Backlight LED	Cathode: blue

SMARTSWITCH™

SUPER BRIGHT LED SPECIFICATIONS

Typical Electrical Characteristics (Temperature at 25°C)

Backlight Color	Symbols	Yellow/Blue	Unit
Forward Current	I_F	15/15	mA
Forward Voltage	V_F	2.2/3.4	V

ABSOLUTE MAXIMUM FOR LEDS

Electrical Characteristics (Temperature at 25°C)

Backlight Color	Symbols	Yellow/Blue	Unit
Forward Current	I_F	20	mA
Reverse Voltage	V_R	4.0	V
Current Reduction Rate Above 25°C	$\Delta I_F(\text{DC})$	-0.26	mA/°C
Power Dissipation*	P_D	130 maximum	mW

*For uniform light emission, Power Dissipation should not exceed the Absolute Maximum Rating.

TYPICAL SWITCH DIMENSIONS

See Pixel Detail

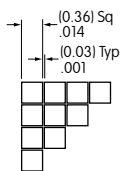
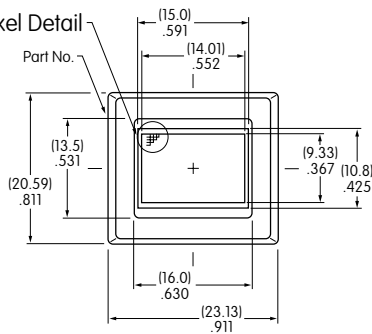

Pixel Detail

See Standoff Detail

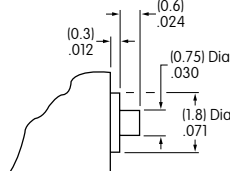
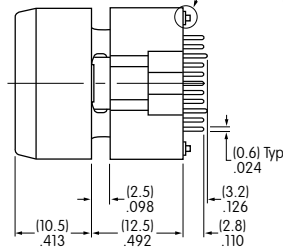

Standoff Detail

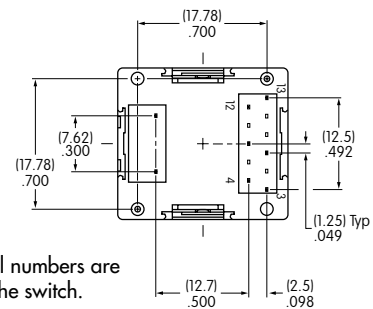

Terminal numbers are not on the switch.

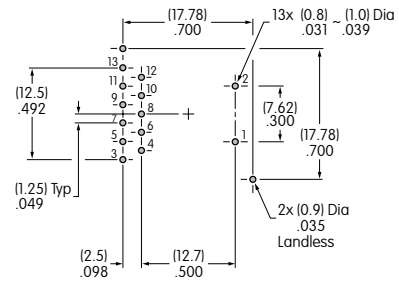

Footprint

PRECAUTIONS FOR HANDLING & STORAGE

Handling

1. The VLC voltage should not be applied before logic voltage. If VLC voltage is present before logic voltage, it may cause the driver logic to freeze and damage the LCD, and the driver logic itself may become damaged.
2. The IS Series devices are electrostatic sensitive.
3. Limit operating force to keytop to 100.0N maximum, as excessive pressure may damage LCD device.
4. Recommended soldering time and temperature limits are 5 seconds maximum @ 270°C maximum.
5. Do not exceed 60°C at the LCD level.
6. The IS series devices are not process sealed.
7. If the LCD is accidentally broken, avoid contact with the liquid and wash off any liquid spills to the skin or clothing.
8. Clean cap surface with dry cloth. If further cleaning is needed, wipe with dampened cloth using neutral cleanser and dry with clean cloth. Do not use organic solvent.



Storage

1. Store away from direct sunlight.
2. Keep away from static electricity.
3. Avoid extreme temperatures, high humidity, gaseous substances, and all forms of chemical contamination.