

Excellent Integrated System Limited

Stocking Distributor

Click to view price, real time Inventory, Delivery & Lifecycle Information:

[FCI](#)

[71609-305LF](#)

For any questions, you can email us directly:

sales@integrated-circuit.com

Copyright FCI



FCIconnect.com

PRODUCT NUMBER
71609-XXXXLF

ROHS COMPATIBLE, SEE NOTE 6

OPTIONAL LETTER
A: PRODUCT PACKED IN TAPE & REEL, SEE TAB56.
NUMBER OF POSITIONS PER ROW: 02 TO 40.

PLATING CODE

- 3= 0.76µm GOLD ON CONTACT AREA.
2µm MIN MATTE TIN ON TAIL.
- 4= 2µm MIN MATTE TIN FULL PLATED
- 8= 0.38µm GOLD ON CONTACT AREA.
2µm MIN MATTE TIN ON TAIL.
- 1.27µm Ni MIN UNDERPLATING

NOTES:

- 1 - HOUSING MAT'L: THERMOPLASTIC GLASS FILLED FLAME RETARDANT PER UL 94 V-0 COLOR: GREY.
 - 2 - TERMINAL MATERIAL: PHOSPHOR BRONZE.
 - 3 - 2 UP TO 4 POSITIONS PRODUCT PACKED IN PLASTIC BOX.
 - 5 UP TO 40 POSITIONS PRODUCT PACKED IN TUBE.
 - 4 - TO DETERMINE DIMENSIONS:
N = NUMBER OF POSITIONS PER ROW
EXAMPLE: 8 POS: (N x 2.54) - 0.08 = 20.24 mm
 - 5 - RECOMMENDED IR PROFIL PER TA 842.
 - 6 - ROHS COMPATIBLE PRODUCT SPECIFICATIONS
- d - PLATING:
- "LF" MEANS THE PRODUCT IS LEAD-FREE, 2µm MINIMUM MATTE TIN OVER 1.27µm MINIMUM NICKEL UNDERPLATE.
- b - MANUFACTURING PROCESS COMPATIBILITY
- THE HOUSING WILL WITHSTAND EXPOSURE TO 260°C PEAK TEMPERATURE FOR 30 SECONDS MAX IN A CONVECTION, INFRA-RED OR VAPOR PHASE OR REFLOW OVEN.
- c - LABELING:
- MEETS PACKAGING SPECS AS PER GS-14-920
- d - LEGAL STATEMENT: SEE GS-47-0004

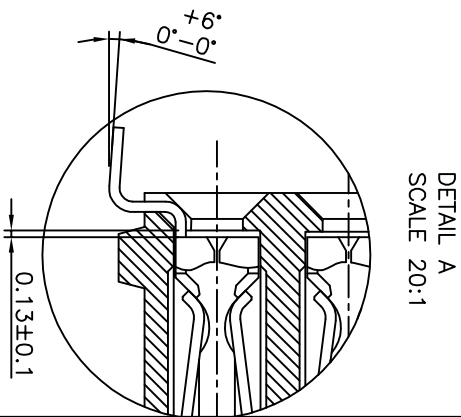
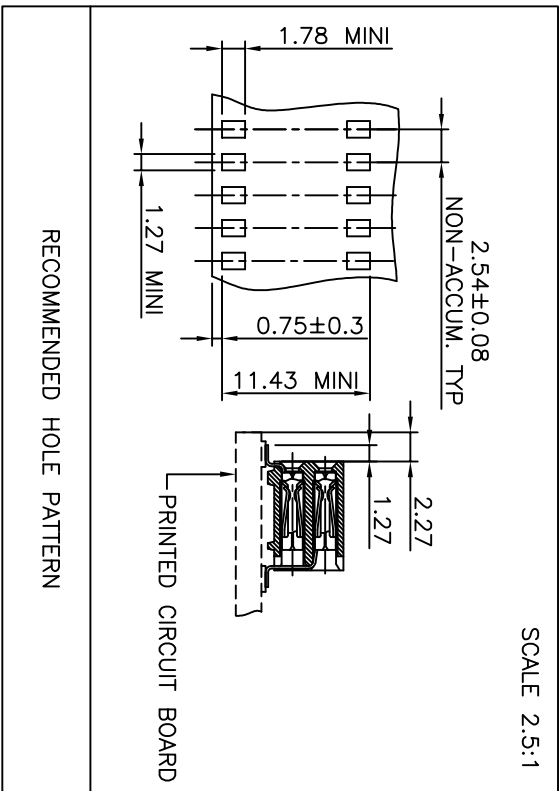
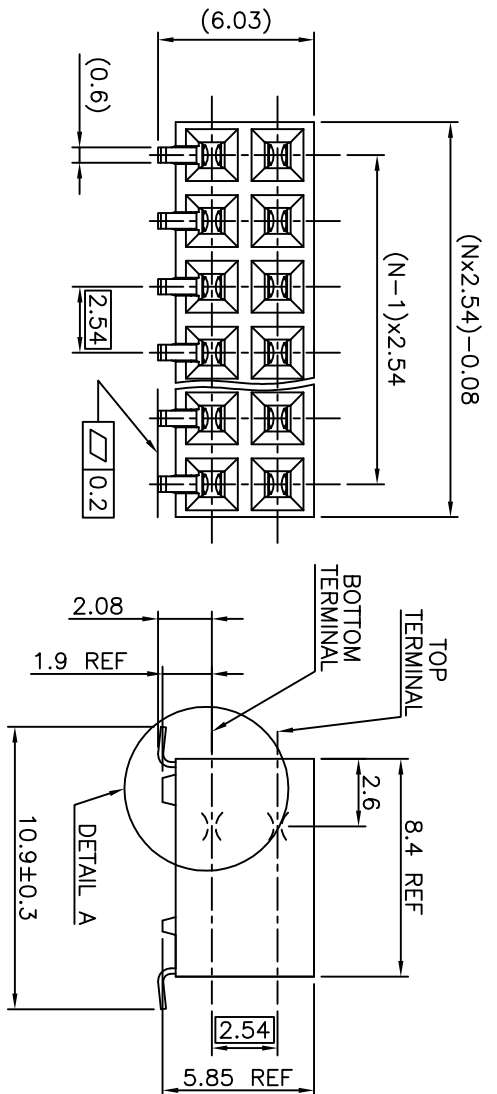

mat'l. code	surface	tolerance	projection	product family
SEE NOTE 1	ISO 1302	ISO 406 ISO 1101	mm	DUBOX
lfr ecn no dr	date	tolerances unless otherwise specified	angles	title
W F04-0347 DLE 04.11.08			40.3	BtB RECEPT.
X F06-0204 DLE 06.06.10				HORIZ DR SMT
Y B-17361 JCO 14.01.04	ISO #		scale 10:1	
AA B-19123 LMU 14.10.21	dr	P.NIZZI	94.03.21	sheet 1 of 1
	engr	P NIZZI	99.06.08	
	chr	JF NOTTEAU	97.05.13	
	appd	PNZ	99.06.08	
sheet	revision			
index	sheet			

form A3

1

2

3

4

5

1

2

3

4

5